

VENTUS ELECTRIC CHAIN WINDER SCE300 & SCE100

compatible Alspec system:

**Awning &
Casement
Windows**



With a simple design and boasting low noise operation, the Ventus Electric Chain Winder can be used on any residential and commercial application. Also compatible with Alspec sections ASW48 and ASW49 concealed winder base and cover, allowing seamless integration with the range of Alspec and Carinya Awning Window systems.



1345590 | 1345595 | 1345591



1345580

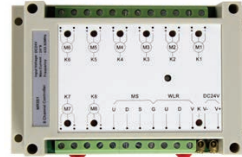

1345581



1345584



1345585



1345582 | 1345592



1345583 | 1345593



1345586



1345587



1345589



1345596



1345597

Alspec Code	Item Description
1345590	VENTUS ELECTRIC CHAIN WINDER SCE300S 300mm SILVER
1345595	VENTUS ELECTRIC CHAIN WINDER SCE300 300mm BLACK
1345591	VENTUS ELECTRIC CHAIN WINDER SCE100S 100mm
1345580	VENTUS MR536 SINGLE CH CONTROLLER DC24V 10AMP
1345581	VENTUS MR551 8 CH CONTROLLER DC24V 2.8AMP
1345584	VENTUS POWER PACK DC24V 2.5 AMP
1345585	VENTUS POWER PACK DC24V 10 AMP
1345582	VENTUS C2075F01 FEMALE PLUG CABLE 100mm 2 CORE
1345583	VENTUS C2075M01 MALE PLUG CABLE 100mm 2 CORE
1345592	VENTUS C2075F3 FEMALE PLUG CABLE 3m 2 CORE
1345593	VENTUS C2075M3 MALE PLUG CABLE 3m 2 CORE
1345586	VENTUS S102P SYNCHRONIZER CONTROL UNIT
1345587	VENTUS RT111 HAND HELD REMOTE TRANSMITTER
1345589	VENTUS WT211 WALL PAD TRANSMITTER
1345596	VENTUS WLR001 WIND LIGHT RAIN SENSOR DC24V 6m CABLE
1345597	VENTUS C405F3 FEMALE PLUG CABLE 3m 4 CORE

SPECIFICATIONS

VOLTAGE	24V DC
PEAK AMP	1.0
NORMALAMP	0.4 - 0.6
PUSH/PULL FORCE	250N
CHAIN MATERIAL	304 STAINLESS STEEL
CHAIN LENGTH	
SCE300S	300mm
SCE100S	100mm

SASH CONSTRAINTS

	1x WINDER	2x WINDERS
MAX SASH HEIGHT	1500mm	1500mm
MAX SASH WIDTH	1200mm	2400mm
MAX SASH WEIGHT	25kg	50kg
MAX SASH SIZE m ²	1.8m ²	2.88m ²

VENTUS ELECTRIC CHAIN WINDER ORDERING GUIDE

STEP 1: SELECT ELECTRIC WINDER REQUIREMENTS (select A or B)

NOTE: USE 100mm CHAIN OPTION FOR RESTRICTED OPENING REQUIREMENTS

A. SASH WIDTH LESS THAN 1200mm AND LESS THAN 25kg

1345590	VENTUS ELECTRIC CHAIN WINDER SCE300S 300mm	1 per window	QTY:
or			
1345591	VENTUS ELECTRIC CHAIN WINDER SCE100S 100mm	1 per window	QTY:



1345590 | 1345591

B. SASH WIDTH GREATER THAN 1200mm AND HEAVIER THAN 25kg

1345590	VENTUS ELECTRIC CHAIN WINDER SCE300S 300mm	2 per window	QTY:
or			
1345591	VENTUS ELECTRIC CHAIN WINDER SCE100S 100mm	2 per window	QTY:



1345590 | 1345591

1345586

SYNC UNIT

1345586	VENTUS S102P SYNCHRONIZER CONTROL UNIT	1 per window	QTY:
---------	--	--------------	------

STEP 2: SELECT TRANSMITTER REQUIREMENTS

1345587	RT111 HAND HELD REMOTE TRANSMITTER	1	QTY:
or / and			
1345589	WT211 WALL PAD TRANSMITTER	1	QTY:



1345587



1345589

STEP 3: SELECT CHANNEL CONTROL UNIT

A. SINGLE WINDOW

1345580	MR536 SINGLE CHANNEL CONTROLLER DC24V 10AMP	1	QTY:
---------	---	---	------



1345580



1345581

B. 2 - 8 WINDOWS

1345581	MR551 8 CHANNEL CONTROLLER DC24V 2.8AMP	1	QTY:
---------	---	---	------

STEP 4: SELECT POWER PACK

A. 1 - 4 WINDOWS

1345584	POWER PACK DC24V 2.5AMP	1	QTY:
---------	-------------------------	---	------



1345584



1345585

B. 5 - 8 WINDOWS

1345585	POWER PACK DC24V 10 AMP	1	QTY:
---------	-------------------------	---	------

STEP 5: SELECT CABLE REQUIREMENTS

1345582	C2075F01 FEMALE PLUG CABLE 100mm	1	QTY:
1345583	C2075M01 MALE PLUG CABLE 100mm	1 per window	QTY:
or			
1345592	C2075F3 FEMALE PLUG CABLE 3m	1	QTY:
1345593	C2075M3 MALE PLUG CABLE 3m	1 per window	QTY:



1345582 | 1345592



1345583 | 1345593

VENTUS ELECTRIC CHAIN WINDER WIRING GUIDE

ELECTRIC CHAIN WINDER INSTALLATION - DOUBLE CHAIN WINDER CONFIGURATIONS

1 WINDOW

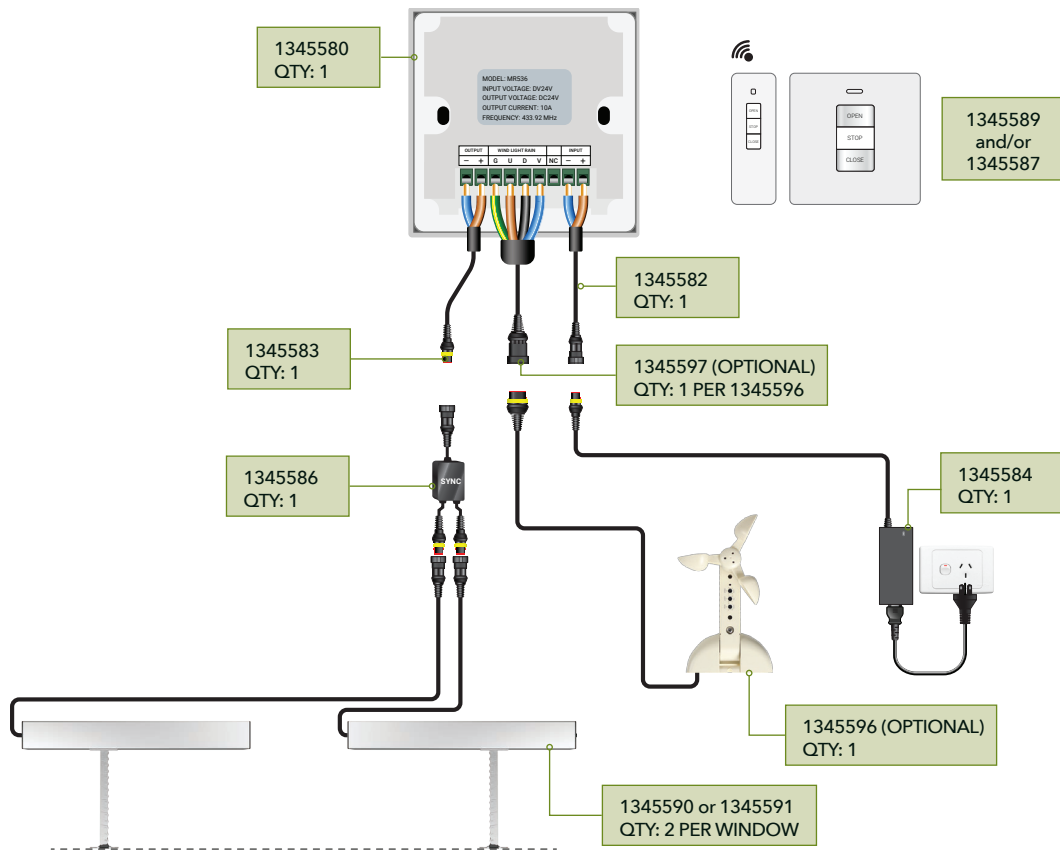

2 TO 4 WINDOWS

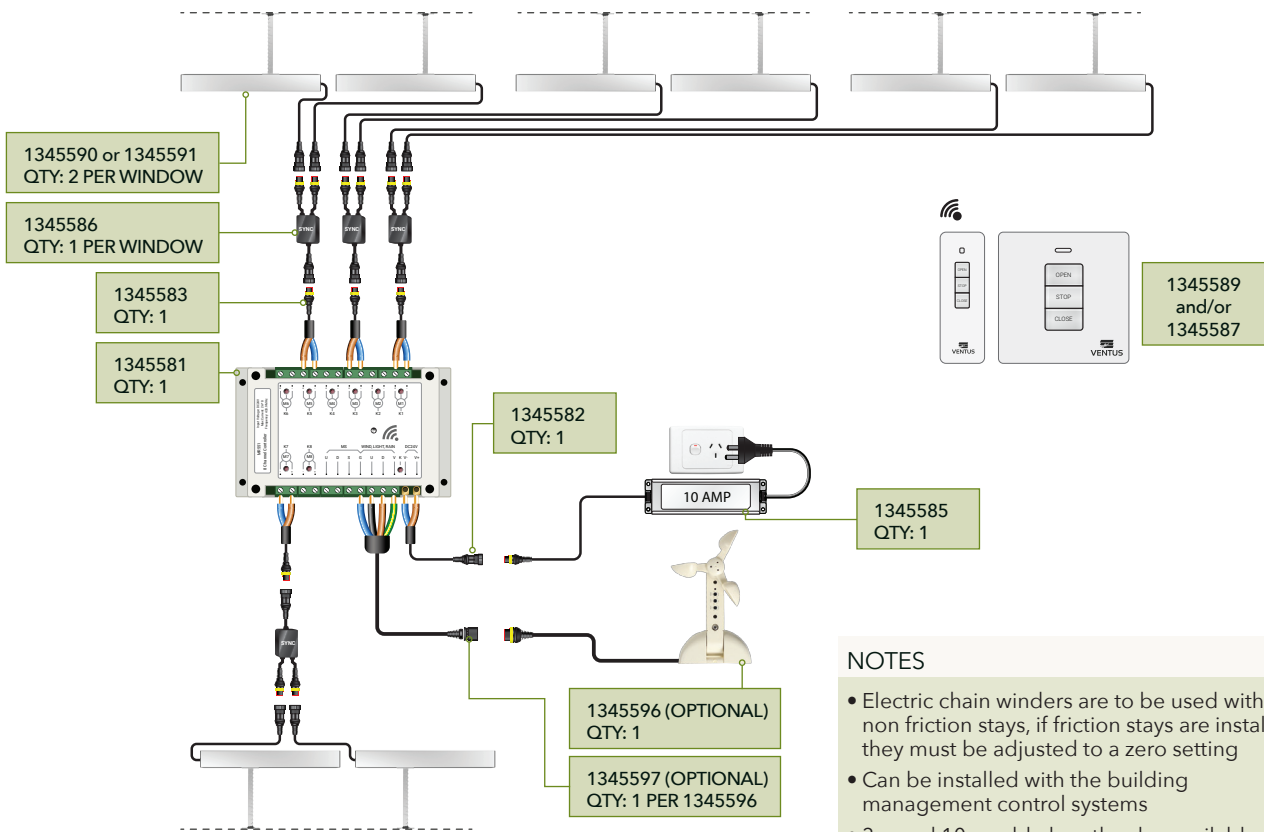

NOTES

- Electric chain winders are to be used with non friction stays, if friction stays are installed they must be adjusted to a zero setting
- Can be installed with the building management control systems
- 3m and 10m cable lengths also available upon request