

CUSTOMER TECHNICAL MEMO # 159

Subject: New Dies: AS25C, AS566, AS1857, AS2365, ECO270, ECO225, AD008, AS1855, AS142s, LV95, LV96

Date: 08/03/13

Good afternoon all,

Please refer below for ALSPEC codes and descriptions of various new extrusions now available for order. Drawings have been attached for your information.

COMMERCIAL FRAMING

AS1857 150MM DISBALED ACCESS THRESHOLD

New Die – Screw flutes suit McArthur, ecoFRAMEplus and Hunter Evo

AS2365 150MM REBATE THRESHOLD

New Die – Screw flutes suit McArthur, ecoFRAMEplus and Hunter Evo

AD008 100MM REBATE THRESHOLD

Shape has been updated, same part number retained.

Screw flutes now suit McArthur, ecoFRAMEplus and Hunter Evo

AS1855 100MM REBATE THRESHOLD

Shape has been updated, same part number retained.

Screw flutes now suit McArthur, ecoFRAMEplus and Hunter Evo

DERWENT

AS566 SELF MATING MULLION

New die – 76mm Self Mating Mullion

AS142s 76mm Sub Sill

New die – 76mm Sub sill – pre slotted

McArthur

AS25c CAPTIVE HOLLOW TRANSOM

New die – 100mm CAPTIVE TRANSOM

ecoFRAMEplus

ECO270 150mm HOLLOW TRANSOM

New die – 150mm HOLLOW TRANSOM

ECO225 100mm HOLLOW TRANSOM

New die – 150mm HOLLOW TRANSOM

Fixed Louvres

LV95 - 2 STAGE LOUVRE

New die – 2 stage chevron louvre

LV96 – STORM LOUVRE

New die – Fixed storm louvre, fits within 100mm McArthur, lines up with screw flutes

If you have any questions please do not hesitate to contact your local ALSPEC Area Manager or Sales Office.

Extrusions

AS1855
100mm THRESHOLD

Mass. 1.202 Kg/m
Anod. Per. 370
Paint Per. 143

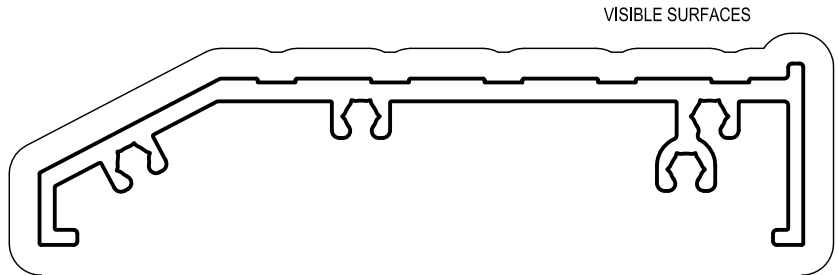

AD008
100mm DISABLED
RAMP THRESHOLD

Mass. 0.953 Kg/m
Anod. Per. 330
Paint Per. 129

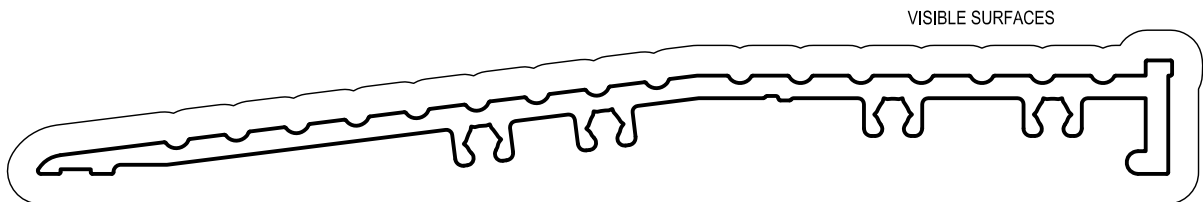
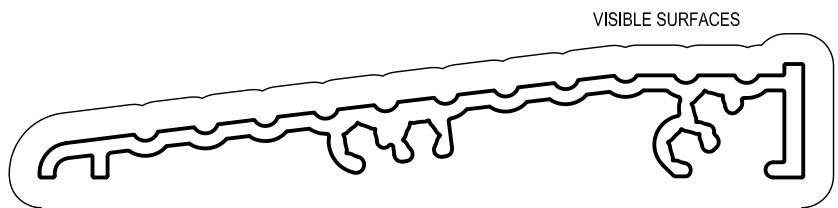

AS1857
150mm THRESHOLD

Mass. 1.439 Kg/m
Anod. Per. 422
Paint Per. 181

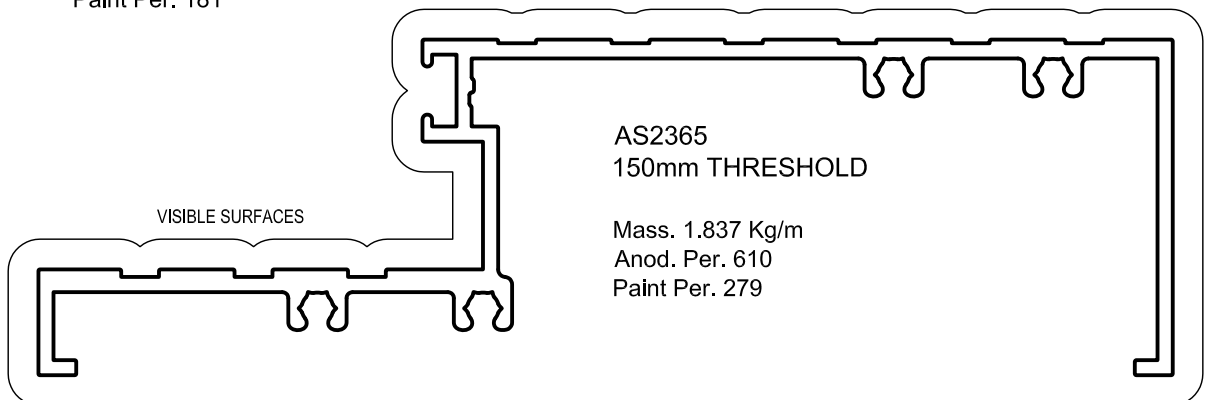

AS2365
150mm THRESHOLD

Mass. 1.837 Kg/m
Anod. Per. 610
Paint Per. 279

Extrusions

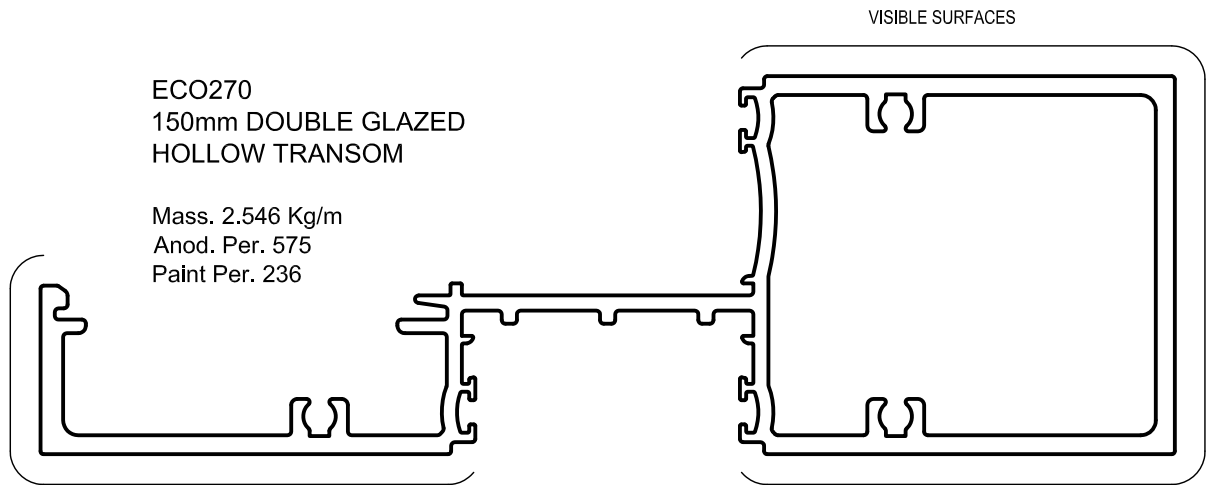

ECO225
100mm DOUBLE GLAZED
HOLLOW TRANSOM

Mass. 1.964 Kg/m
Anod. Per. 478
Paint Per. 163

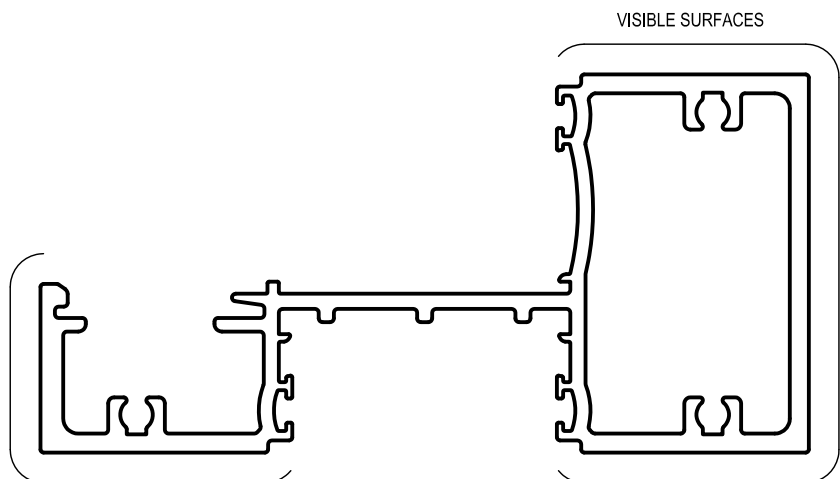

AS25C
100mm CAPTIVE
HOLLOW TRANSOM

Mass. 1.697 Kg/m
Anod. Per. 474
Paint Per. 194

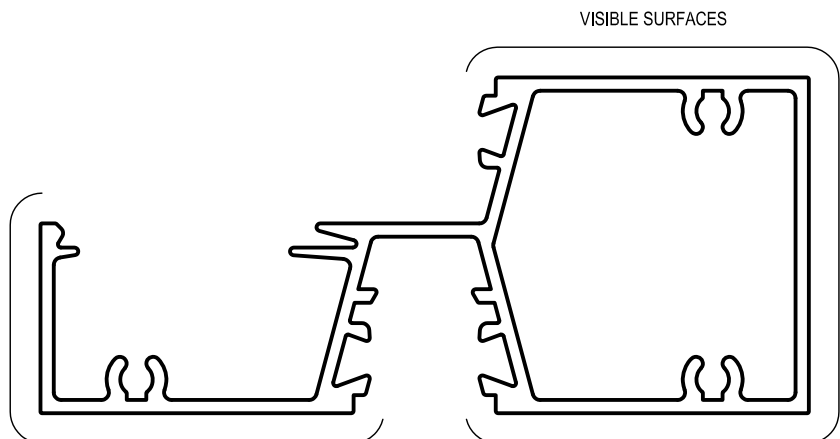

Extrusions

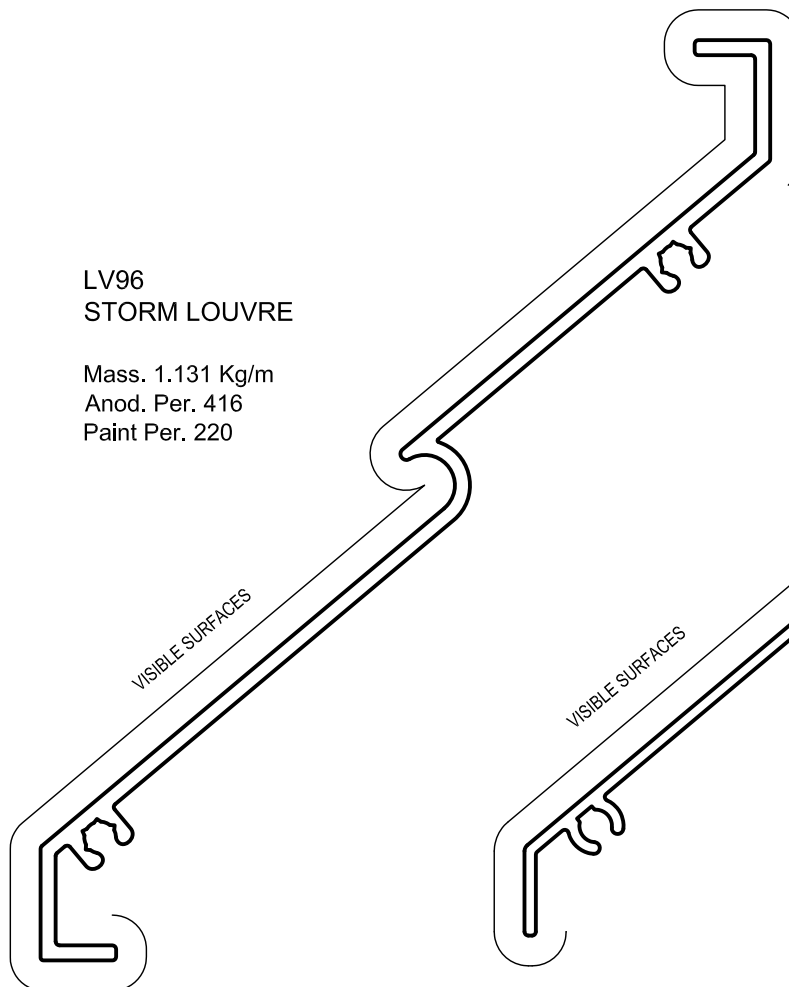
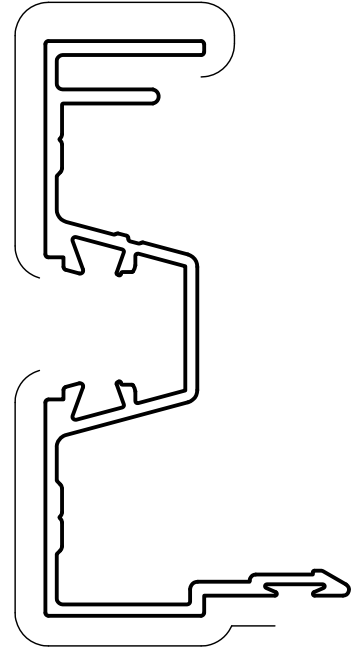
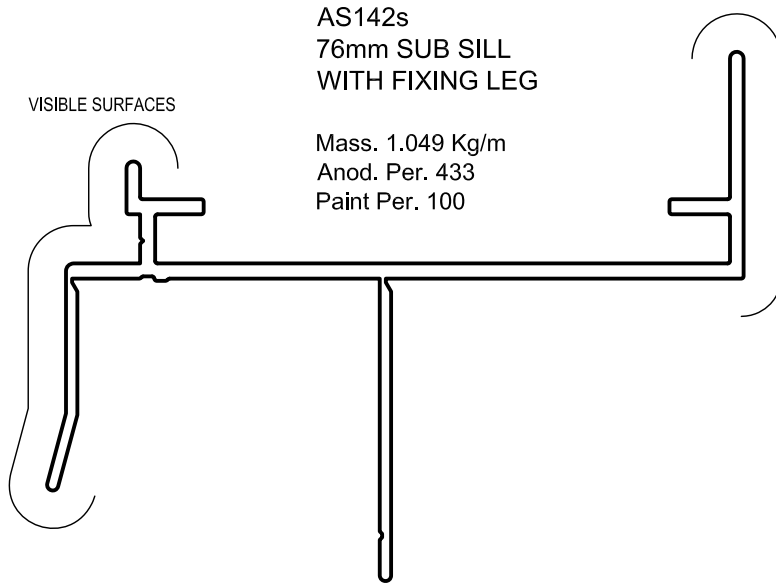

AS566
76mm SELF
MATING MULLION

Mass. 0.955 Kg/m
Anod. Per. 401
Paint Per. 113

