

CUSTOMER TECHNICAL MEMO # 190

Subject: NEW DIES – SUB HEADS AND SUB SILLS

Date: 15.11.13

From: Product Development

Good Afternoon all,

Please refer attached for new dies now available.

AS609 DEEP 150MM SUB-HEAD

AS149S 100MM EXTENDED SUB SILL

AS145S FACE SUB-SILL SLOTTED

AS154S EXTENDABLE 100MM SUB SILL

AS155S EXTENDABLE 150MM SUB SILL

AS156 EXTENDABLE SUB SILL FRONT

AS628S HD EXTENDED LEG SUB-SILL

If you have any questions please do not hesitate to contact your local Area Manager or Sales Office.

Kind Regards,

Product Development

Extrusions

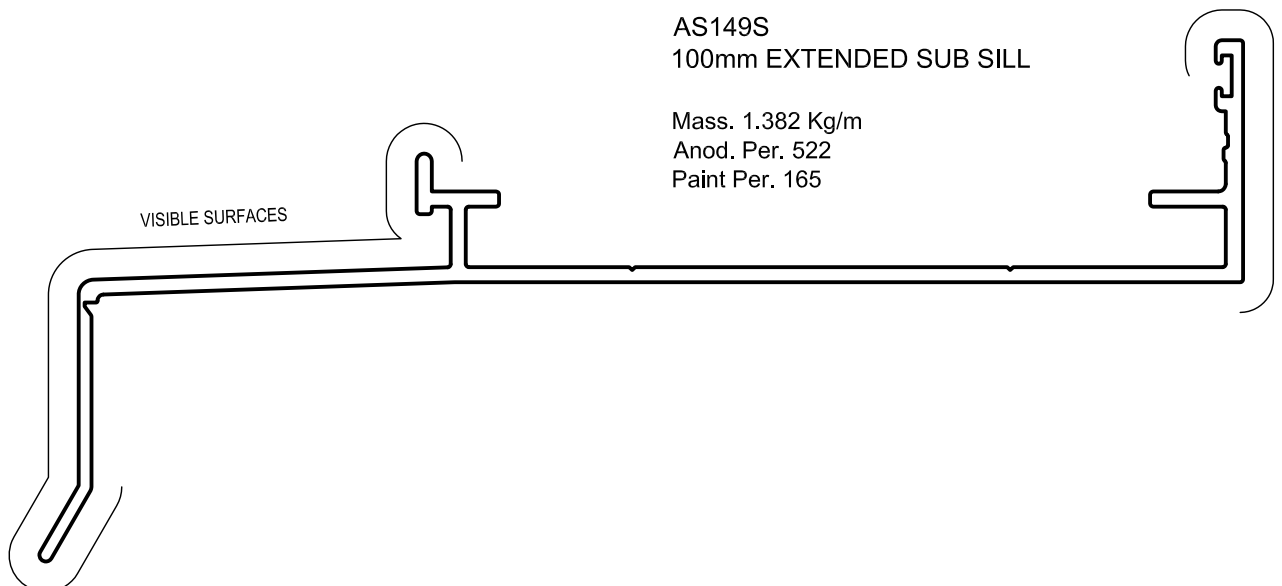
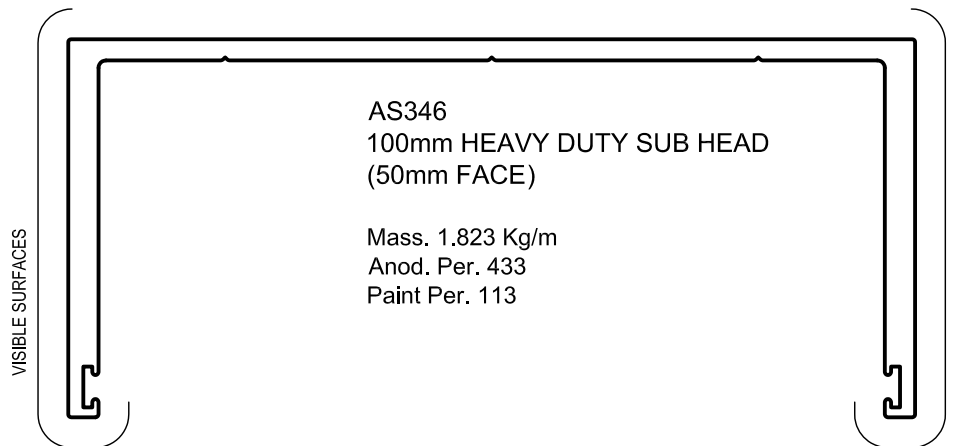
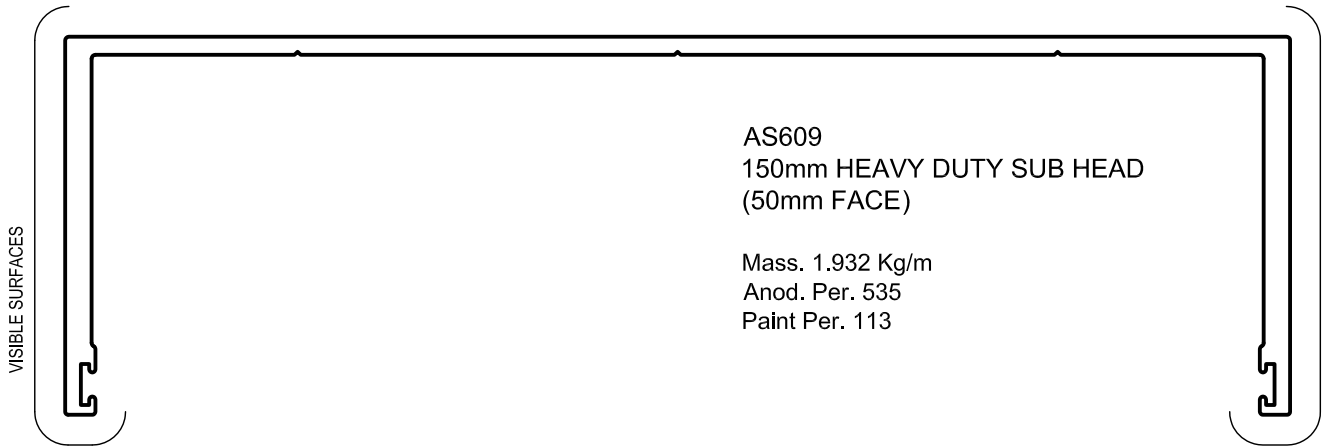

Extrusions

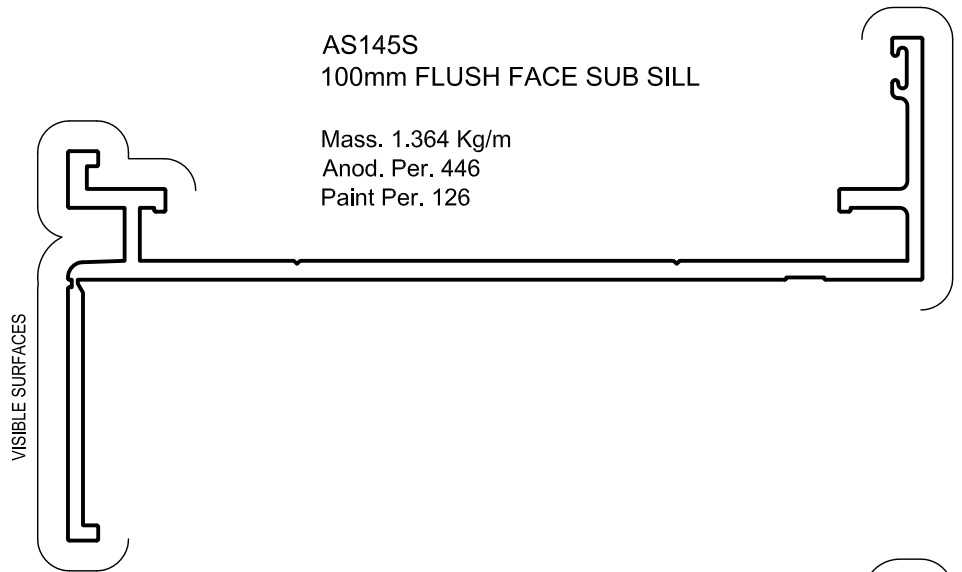

AS145S
100mm FLUSH FACE SUB SILL

Mass. 1.364 Kg/m
Anod. Per. 446
Paint Per. 126

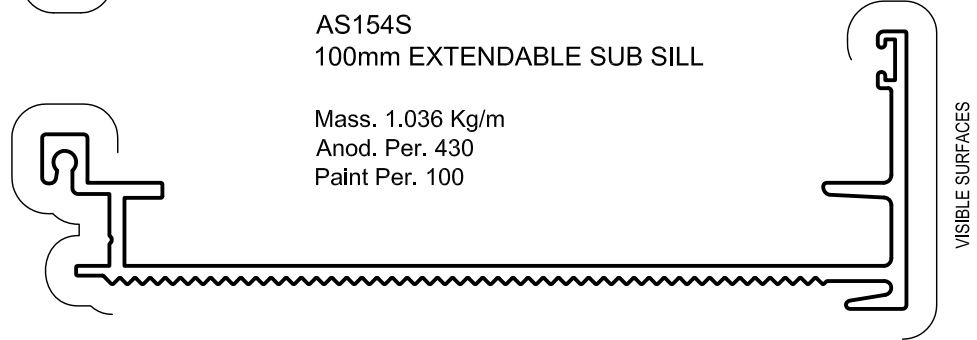

AS154S
100mm EXTENDABLE SUB SILL

Mass. 1.036 Kg/m
Anod. Per. 430
Paint Per. 100

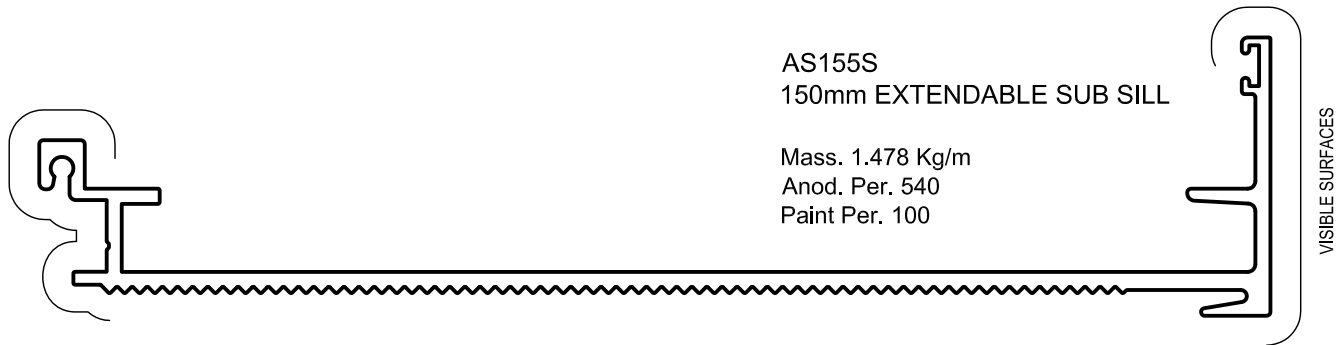

AS155S
150mm EXTENDABLE SUB SILL

Mass. 1.478 Kg/m
Anod. Per. 540
Paint Per. 100

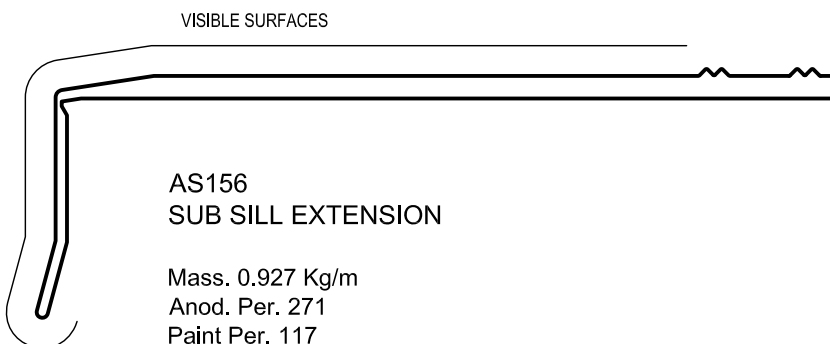

AS156
SUB SILL EXTENSION

Mass. 0.927 Kg/m
Anod. Per. 271
Paint Per. 117

Extrusions

