

## CUSTOMER TECHNICAL MEMO # 229

**Subject: ProGlide Clip In Screen Adaptors AD787, AD788, AD789**

**Date:** August 2015

Good Morning All,

We are pleased to advise that as part of our ongoing system development we have developed new Clip In Screen Adaptors used on 3 track ProGlide sections to screen 2 track sliding doors in XO and OXXO configurations.

Section details are as follows:

<b>Code</b>	<b>Description</b>
1602504	<b>AD787 PROGLIDE SCREEN HEAD ADAPTOR</b>
1602505	<b>AD788 PROGLIDE SCREEN SILL ADAPTOR</b>
1602506	<b>AD789 PROGLIDE SCREEN JAMB ADAPTOR</b>

These new sections appear on the revised ProGlide Wall Chart on the ALSPEC website and will be included in the next release of the updated ProGlide Technical Manual. Until this Tech Manual update is finalised the pages have been attached for your information.

These sections will be programmed into AiQ for future releases.

If you have any questions please do not hesitate to contact your local ALSPEC Area Manager or Sales Office.



**EXTRUSION - SCREEN FRAMING**

VISIBLE SURFACE

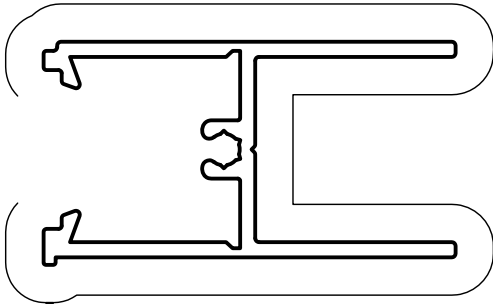

**AD759**  
SCREEN DOOR  
ADAPTOR JAMB

Mass. 0.831 Kg/m  
Anod. Per. 310  
Paint Per. 199

VISIBLE SURFACE

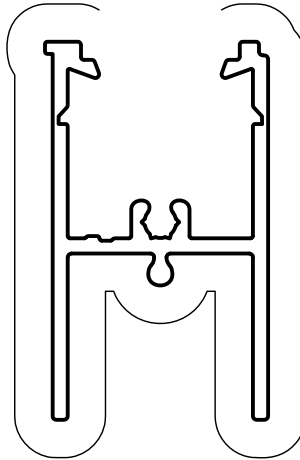

**AD760**  
SCREEN DOOR  
ADAPTOR HEAD

Mass. 0.806 Kg/m  
Anod. Per. 301  
Paint Per. 189

VISIBLE SURFACE

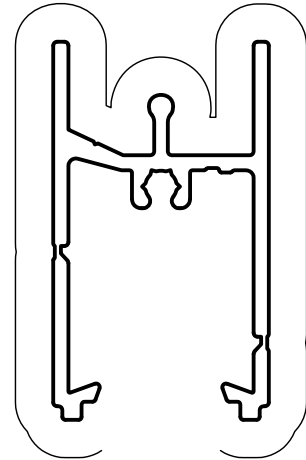

**AD761**  
SCREEN DOOR  
ADAPTOR SILL

Mass. 0.831Kg/m  
Anod. Per. 305  
Paint Per. 118

VISIBLE SURFACE

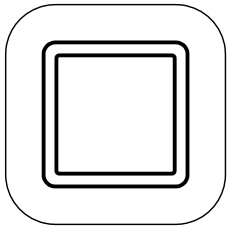

**SB2**  
BOX RADIUS  
19.05 x 1.7mm

Mass. 0.315 Kg/m  
Anod. Per. 100  
Paint Per. 100

VISIBLE SURFACE

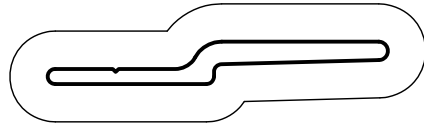

**HD22**  
HEAVY DUTY  
STEPPED  
INTERLOCK

Mass. 0.306Kg/m  
Anod. Per. 100  
Paint Per. 100

vs

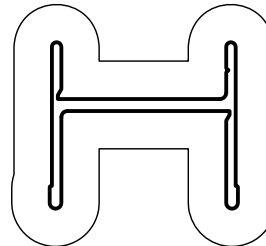

**ST9**  
RECEIVER  
CHANNEL

Mass. 0.244 Kg/m  
Anod. Per. 133  
Paint Per. 133

VISIBLE SURFACE

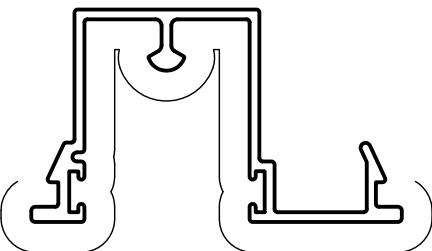

**AD787**  
SCREEN HEAD  
ADAPTOR

Mass. 0.493 Kg/m  
Anod. Per. 259  
Paint Per. 140

vs

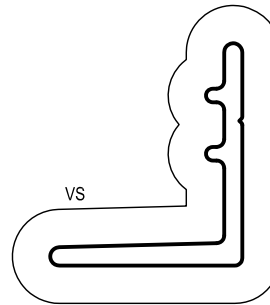

**HD23**  
HEAVY DUTY  
FRAME  
INTERLOCK

Mass. 0.378 Kg/m  
Anod. Per. 114  
Paint Per. 114

VISIBLE SURFACE

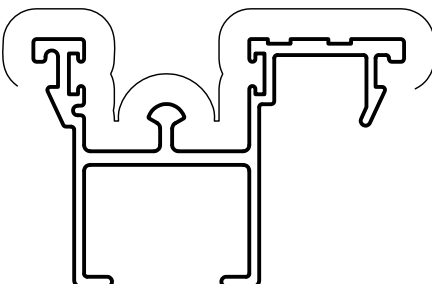

**AD788**  
SCREEN SILL  
ADAPTOR

Mass. 0.620 Kg/m  
Anod. Per. 294  
Paint Per. 118

VISIBLE SURFACE

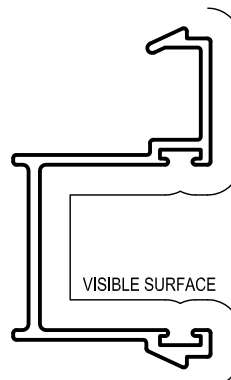

**AD789**  
SCREEN JAMB  
ADAPTOR

Mass. 0.402 Kg/m  
Anod. Per. 214  
Paint Per. 107



**FLYSCREEN DETAILS - 150mm SCREEN ADAPTOR XO**

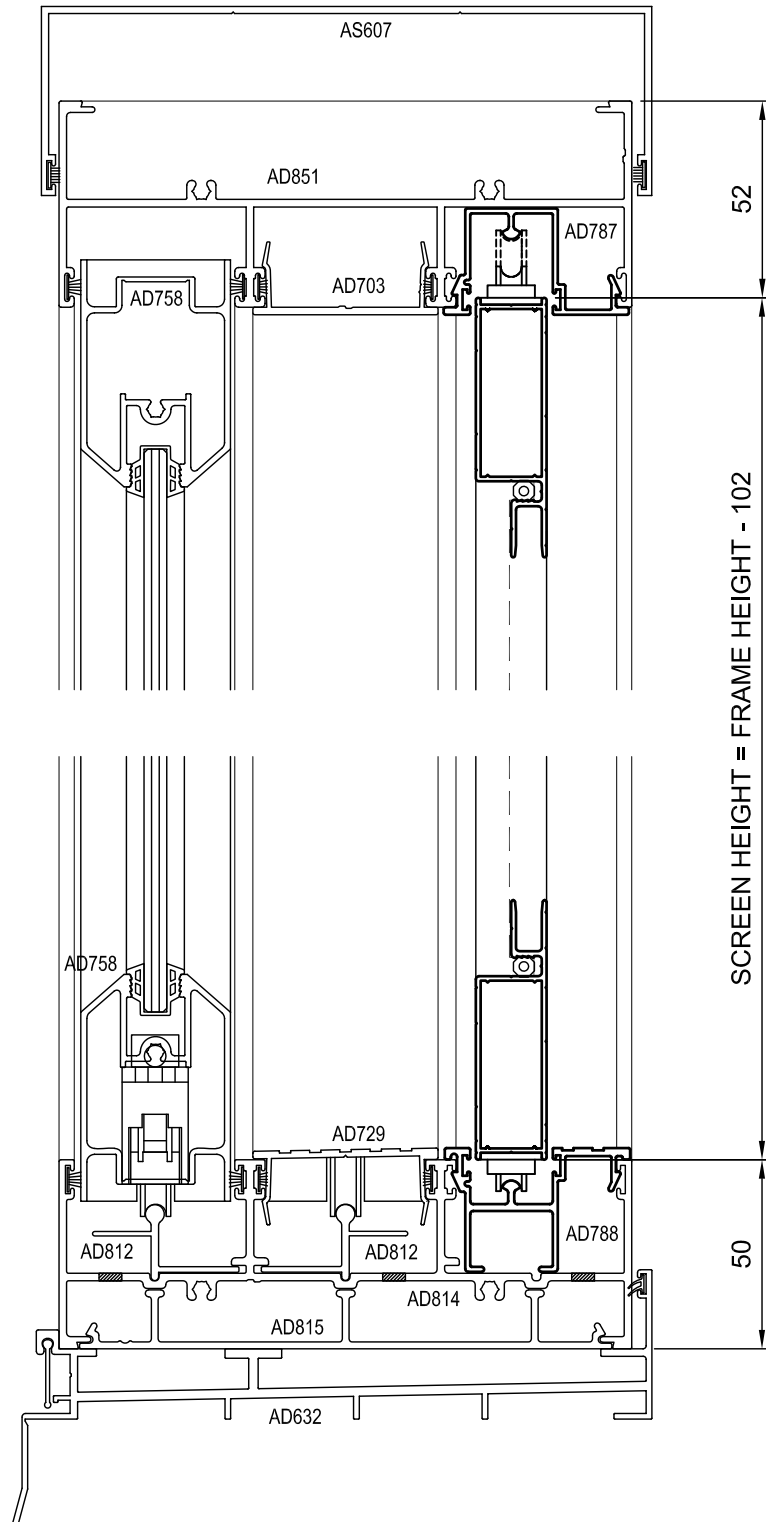

**FLYSCREEN DETAILS - 150mm SCREEN ADAPTOR XO**

