

CUSTOMER TECHNICAL MEMO # 242

Subject: Hawkesbury and Hawkesbury Plus Technical Manual and Wall Chart Extrusions update

Date: August 2015

Good Morning,

Please note the following extrusion pages have been revised in line with changes to the Hawkesbury/Hawkesbury Plus Wall Chart, and should replace the existing pages in your current Technical Manuals. Please note a full Hawkesbury Technical Manual update is in progress and will be released when complete.

Hawkesbury

- Cover Page
- Contents page updated (Extrusions)
- Page 1.0 - Technical Manual Release Notes updated with latest changes
- Pages 3.1.1, 3.1.2, 3.1.7 to 3.1.11 - Extrusions pages amended and or added
- Contacts Page updated (Last page)

Hawkesbury Plus

- Cover Page
- Contents page updated (Extrusions)
- Page 1.0 and 1.1 - Technical Manual Release Notes updated with latest changes
- Pages 3.1.5 to 3.1.8 - Extrusions pages amended and added
- Contacts Page updated (Last page)

All the above pages have been included with this Technical Memo. The format has been set for double sided printing so you will be able to easily replace the current pages in your technical manuals. (You will need to ensure your printer is set to double-sided printing.)

The Hawkesbury and Hawkesbury Plus Technical Manuals and Wall Charts have been updated on the ALSPEC website. A copy of this Customer Technical Memo has also been added to the NEWS/CUSTOMER TECHNICAL MEMO link for future reference.

If you have any questions please do not hesitate to contact your local ALSPEC Area Manager or Sales Office.

ALSPEC ALUMINIUM SYSTEMS

TECHNICAL MANUAL

HAWKESBURY

COPYRIGHT

This Technical manual remains the property of Aluminium Specialties Group Pty Limited and contains privileged information which is the subject of copyright and the manual or any part thereof may not be reproduced, copied or loaned in any form without the written permission of Aluminium Specialties Group Pty Limited.

This manual is to be returned to Aluminium Specialties Group Pty Limited when requested

DISCLAIMER

Whilst every effort has been made to ensure the technical details contained within this manual are accurate, Aluminium Specialties Group Pty Limited can take no responsibilities for any loss or damage whatsoever arising as a result of any errors contained in this manual.

Also, interpretation of standards or codes within this manual is Aluminium Specialties Group Pty Limited interpretation for such codes. Responsibility for code compliance remains with the user of this manual. In some cases product dimensions may vary or be changed without notice. The user of this manual should not act or rely upon on any information contained in this manual without first obtaining appropriate professional advice relating to their particular circumstances.

Aluminium Specialties Group Pty Limited disclaims all liability for loss or damage suffered by any party who acts or fails to act in reliance of this manual.

Issued to:

.....

ALSPEC contact:

Date:

Manual reference number:

ALSPEC ALUMINIUM SYSTEMS

TECHNICAL MANUAL

HAWKESBURY

CONTENTS

1.0 TECHNICAL MANUAL RELEASE NOTES

2.0 TECHNICAL DATA

2.1 SPECIFICATION

2.2 LOADING TABLES

- 2.2.1 MF14 L/180
- 2.2.2 MF14 L/250
- 2.2.3 MF27 L/180
- 2.2.4 MF27 L/250
- 2.2.5 MF227 L/180
- 2.2.6 MF227 L/250
- 2.2.7 MF70 L/180
- 2.2.8 MF70 L/250
- 2.2.9 MF73 L/180
- 2.2.10 MF73 L/250

2.3 TEST REPORTS RESULTS

- 2.3.1 2 Left Open Out, MF100HP Sill, MF27 Door Stiles, AS106 Subsill
- 2.3.2 2 Left Open Out, MFE41S Sill, MF27 Door Stiles, AS106 Subsill
- 2.3.3 2 Left Open Out, MF100HP Sill, MF27 Door Stiles, AS106 Subsill
- 2.3.4 1L, 4R Open Out, MFE41S Sill, MF27 Door Stiles, AS106 Subsill
- 2.3.5 3 Left Open In, MFE41S Sill, MF14 Door Stiles, AS332 Subsill
- 2.3.6 Hawkesbury Folding Door 2 Left Open Out – Acoustic Results
- 2.3.7 Hawkesbury Folding Door 2 Left Open Out – Acoustic Results
- 2.3.8 Hawkesbury Folding Door 2 Left Open Out – Acoustic Results

3.0 TECHNICAL DETAILS

3.1 EXTRUSIONS

- 3.1.1 Extrusion profiles
- 3.1.2 Extrusion profiles
- 3.1.3 Extrusion profiles
- 3.1.4 Extrusion profiles
- 3.1.5 Extrusion profiles
- 3.1.6 Extrusion profiles
- 3.1.7 Extrusion profiles
- 3.1.8 Extrusion profiles
- 3.1.9 Extrusion profiles
- 3.1.10 Extrusion profiles
- 3.1.11 Extrusion profiles

3.2 HARDWARE

- 3.2.1 Hardware components
- 3.2.2 Hardware components
- 3.2.3 Hardware components
- 3.2.4 Hardware components

HAWKESBURY

ALSPEC ALUMINIUM SYSTEMS

TECHNICAL MANUAL

HAWKESBURY

CONTENTS Cont.

- 3.2.5 Hardware components
- 3.2.6 Hardware components
- 3.2.7 Hardware components
- 3.2.8 Hardware components
- 3.2.9 Hardware components
- 3.2.10 Hardware components
- 3.2.11 Hardware components
- 3.2.12 Hardware components
- 3.2.13 Hardware Selection Chart
- 3.2.14 Hardware Selection Chart
- 3.2.15 Hardware Selection Chart
- 3.2.16 Hardware Selection Chart

3.3 ELEVATIONS

- 3.3.1 Typical elevations
- 3.3.2 Typical elevations
- 3.3.3 Typical elevations

3.4 GENERAL ARRANGEMENT DRAWINGS

- 3.4.1 Typical Head and Sill Detail
- 3.4.2 Typical L.H. Jamb Hinge/Intermediate Meeting Stiles & Lock Stile/Jamb Details
- 3.4.3 Typical Lock meeting stile Detail
- 3.4.4 CE23 Weatherseal Arrangement Details
- 3.4.5 External Corner Details
- 3.4.6 Internal Corner Details
- 3.4.7 Weather Strip Assembly
- 3.4.8 Bi-fold Door Flat Sill - Front View
- 3.4.9 Bi-fold Door Flat Sill - Back View

3.5 CUTTING FORMULAS

- 3.5.1 Extrusion cutting formulas
- 3.5.2 Extrusion cutting formulas
- 3.5.3 Extrusion cutting formulas
- 3.5.4 Extrusion cutting formulas
- 3.5.5 Extrusion cutting formulas
- 3.5.6 Extrusion cutting formulas
- 3.5.7 Extrusion cutting formulas
- 3.5.8 Extrusion cutting formulas
- 3.5.9 Extrusion cutting formulas
- 3.5.10 Extrusion cutting formulas
- 3.5.11 Extrusion cutting formulas
- 3.5.12 Extrusion cutting formulas
- 3.5.13 Extrusion cutting formulas
- 3.5.14 Extrusion cutting formulas

HAWKESBURY

ALSPEC ALUMINIUM SYSTEMS

TECHNICAL MANUAL

HAWKESBURY

Section 1.0

TECHNICAL MANUAL RELEASE NOTES

This page is intended to record all changes to the HAWKESBURY technical manual pages. It is therefore critical that all changes are recorded in the below AMENDMENTS box prior to release to our customer.

Changes or additions to this manual will be itemised with a brief description and date when the amendments were made.

It is important that a copy of the page be issued with the update and inserted as the first page in the customers technical manual.

DATE	AMENDMENT DESCRIPTION	REMOVE PAGE	INSERT NEW PAGE
01 / 09 / 2008	<i>Technical manual initial release</i>	~	~
02 / 02 / 2009	<i>Contents pages</i>	~	~
01 / 12 / 2008	<i>Hardware page</i>	3.2.1	3.2.1
01 / 12 / 2008	<i>Typical meeting stile detail</i>	3.4.3	3.4.3
01 / 02 / 2009	<i>Technical manual release notes amended</i>	1.0	1.0
01 / 02 / 2009	<i>Specification amended</i>	2.1	2.1
01 / 02 / 2009	<i>Test drawings added</i>	~	2.3.4 to 2.3.6
01 / 02 / 2009	<i>Gasket drawing amended</i>	3.2.1	3.2.1
01 / 02 / 2009	<i>Hardware</i>	~	3.2.2 to 3.2.9
01 / 02 / 2009	<i>Hardware Selection Charts</i>	~	3.2.10 to 3.2.13
01 / 02 / 2009	<i>Bi fold door flat sill - front view</i>	~	3.4.5
01 / 02 / 2009	<i>Bi fold door flat sill - back view</i>	~	3.4.6
01 / 06 / 2009	<i>Technical manual release notes amended</i>	1.0	1.0
01 / 06 / 2009	<i>Extrusion sections and properties amended</i>	3.1.8	3.1.8
01 / 06 / 2009	<i>Door style preparation for AD1033DG spiggot amended</i>	3.6.6	3.6.6
01 / 06 / 2009	<i>Door rail preparation D.G. image amended</i>	3.6.7	3.6.7
01 / 06 / 2009	<i>Glazing detail D.G. image amended</i>	3.7.2	3.7.2
01 / 02 / 2012	<i>Technical manual revised and updated for re-print</i>	ALL	ALL
01 / 06 / 2015	<i>Cover page amended</i>	Cover Page	Cover Page
01 / 06 / 2015	<i>Extrusion contents page updated</i>	~	~
01 / 06 / 2015	<i>Technical manual release notes updated</i>	1.0	1.0
01 / 06 / 2015	<i>Extrusion updated</i>	3.1.1, 3.1.2, 3.1.8, 3.1.9, 3.1.10	3.1.1, 3.1.2, 3.1.8, 3.1.9, 3.1.10
01 / 06 / 2015	<i>Extrusion pages added</i>	~	3.1.11
01 / 06 / 2015	<i>Contact page updated</i>	Last Page	Last Page

EXTRUSION PROFILES

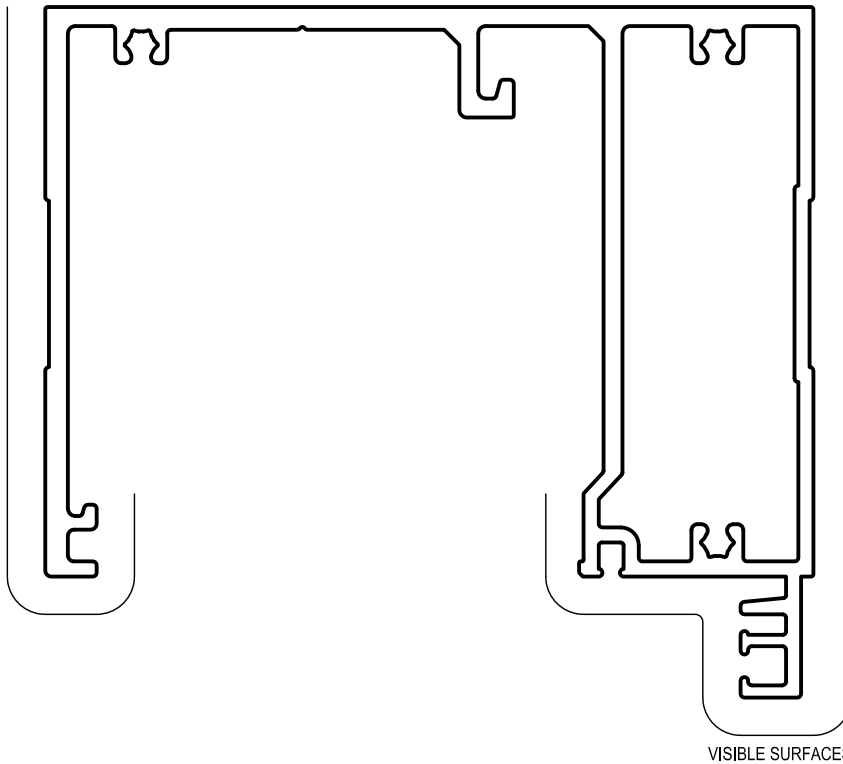

MFE1
E2/E3 HEAD
Mass. 2.877 Kg/m
Anod. Per. 649
Paint Per. 273

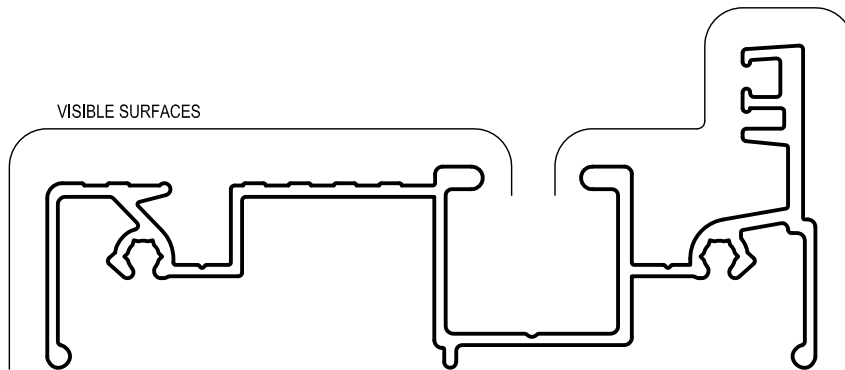

MFE41s
REVERSIBLE SILL
Mass. 1.332 Kg/m
Anod. Per. 557
Paint Per. 330

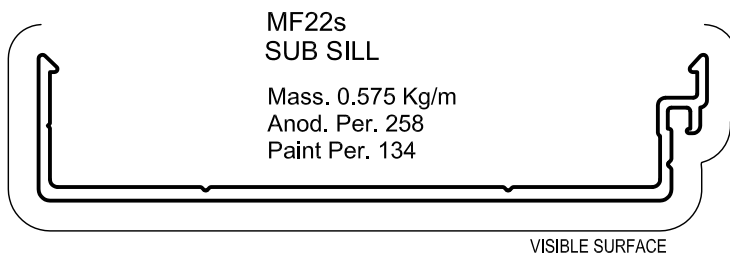

MF22s
SUB SILL
Mass. 0.575 Kg/m
Anod. Per. 258
Paint Per. 134

NOTE: MUST BE STOP ENDED
PRIOR TO INSTALLATION

EXTRUSION PROFILES

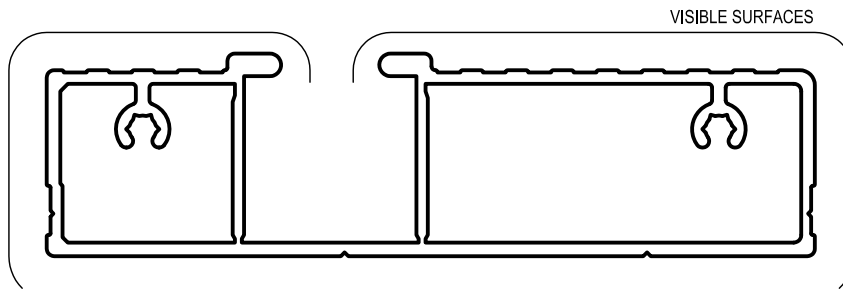

**MFE23
PLAIN SILL**

Mass. 1.449 Kg/m
Anod. Per. 328
Paint Per. 149

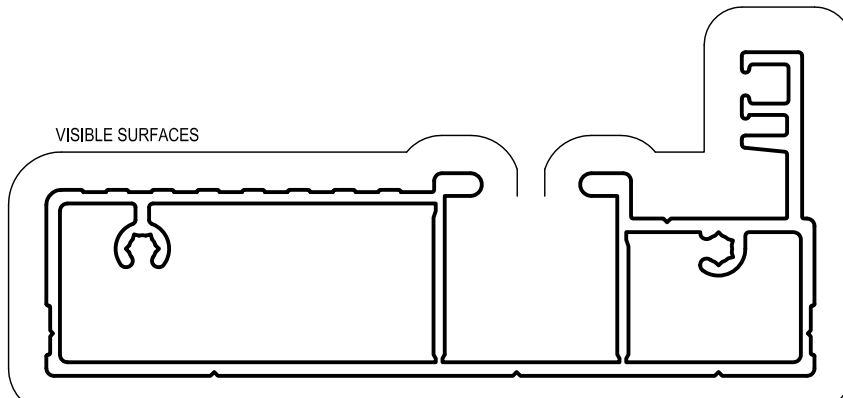

**MFE21
REVERSIBLE SILL**

Mass. 1.609 Kg/m
Anod. Per. 410
Paint Per. 230

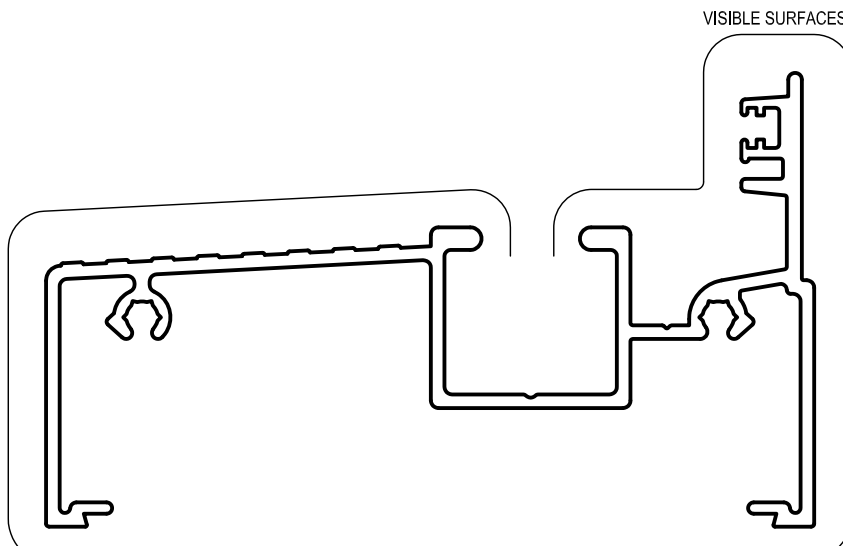

**MF100
HIGH PERFORMANCE
SILL**

Mass. 1.560 Kg/m
Anod Per. 619
Paint Per. 272

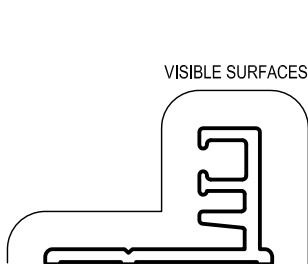

**MFE19
DOOR ADAPTOR**

Mass. 0.313 Kg/m
Anod. Per. 134
Paint Per. 100

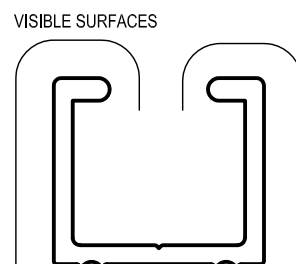

**MFE20D
DEEP SILL TRACK**

Mass. 0.561 Kg/m
Anod Per. 165
Paint Per. 137

EXTRUSION PROFILES

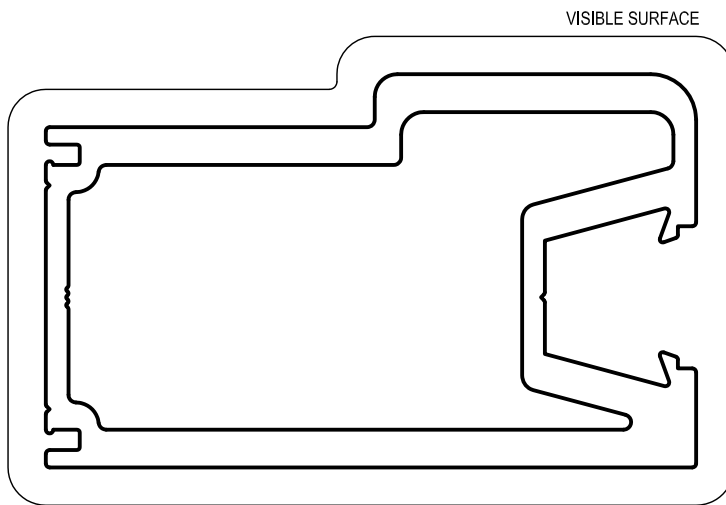

**MF227
EXTRA H.D. DOOR STILE**

Mass. 3.581 Kg/m
Anod. Per. 342
Paint Per. 273

$I_{xx} = 478.50 \times 10^3 \text{mm}^4$

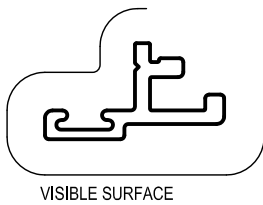

**MFA29
MEETING STILE
ADAPTOR**

Mass. 0.218 Kg/m
Anod. Per. 100
Paint Per. 100

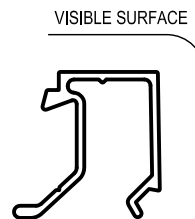

**MF18
DOOR BEAD**

Mass. 0.18 Kg/m
Anod. Per. 122
Paint Per. 100

FOR SINGLE GLAZED DOOR
USE AD1030E SPIGGOT SET
Code No. 378047

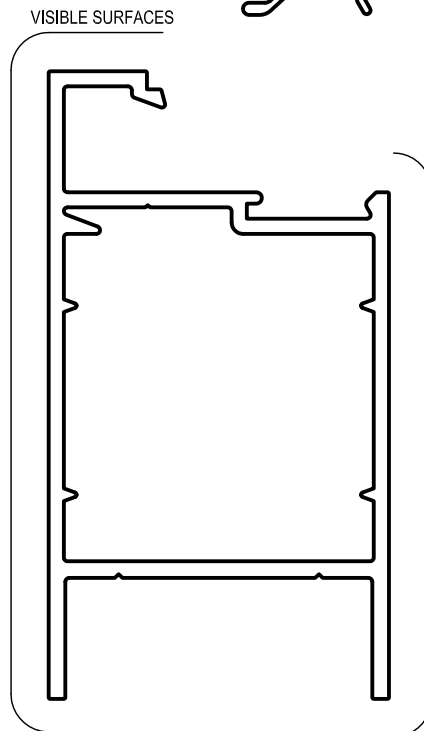

**MF17
DOOR TOP &
BOTTOM RAIL**

Mass. 1.450 Kg/m
Anod. Per. 328
Paint Per. 168

**MF75
WEATHERSEAL
SNAP ON COVER**

Mass. 0.100 Kg/m
Anod. Per. 100
Paint Per. 100

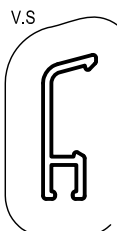

EXTRUSION PROFILES

VISIBLE SURFACE

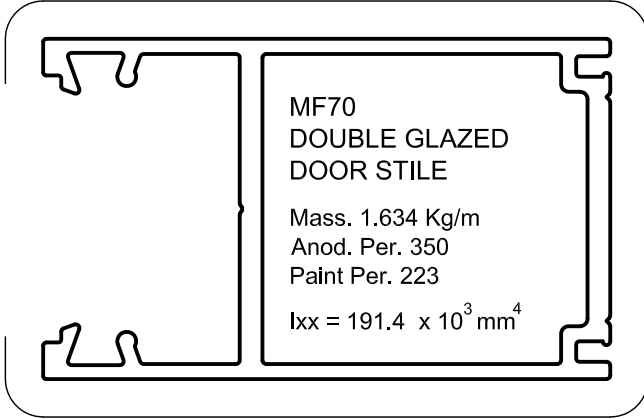

V.S.

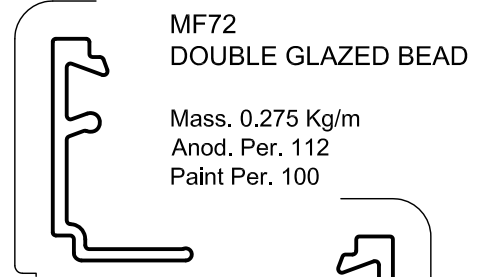

VISIBLE SURFACE

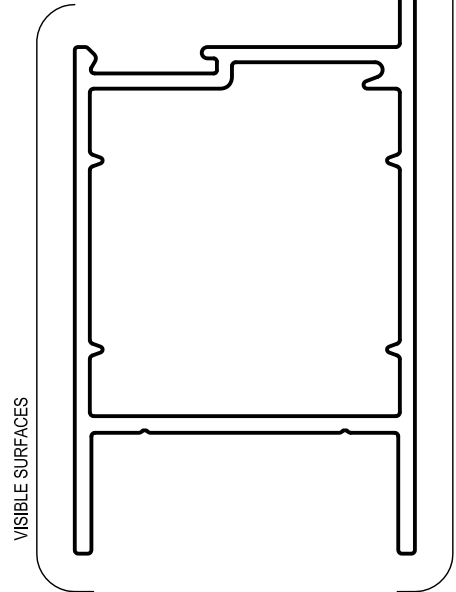
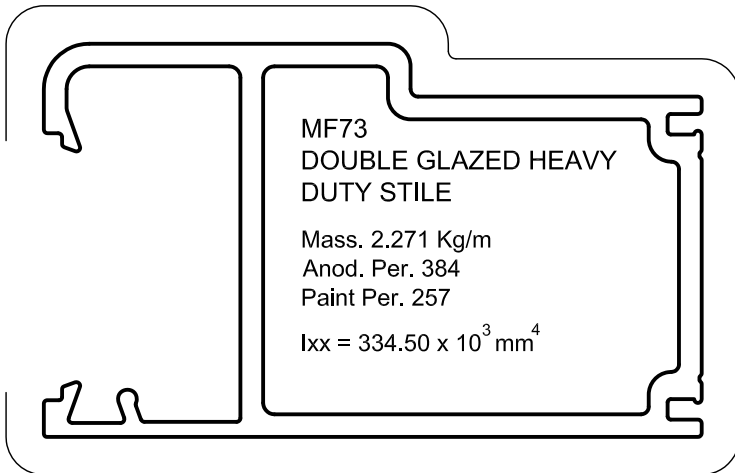

MF71
DOUBLE GLAZED
DOOR RAIL

Mass. 1.494 Kg/m
Anod. Per. 335
Paint Per. 170

VISIBLE SURFACE

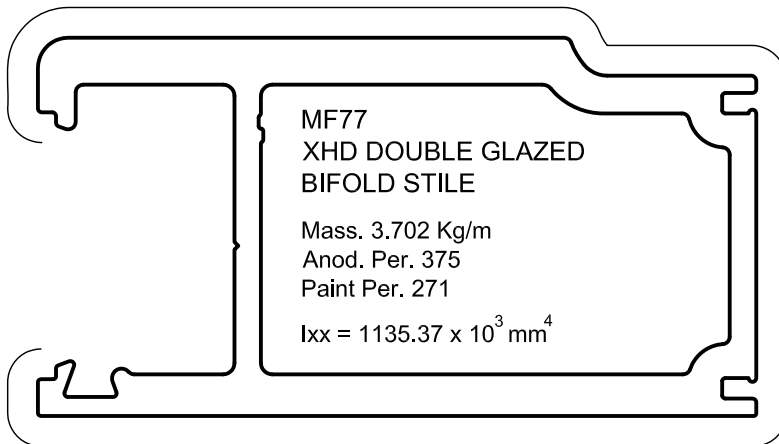

FOR DOUBLE GLAZED DOOR
USE AD1033 SPIGGOT SET
Code No. 378073

EXTRUSION PROFILES

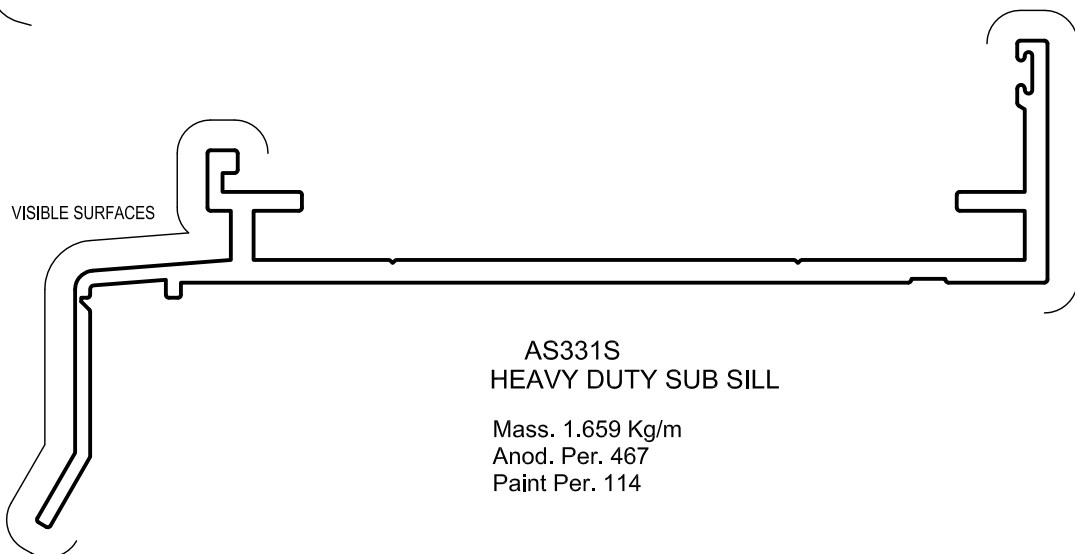
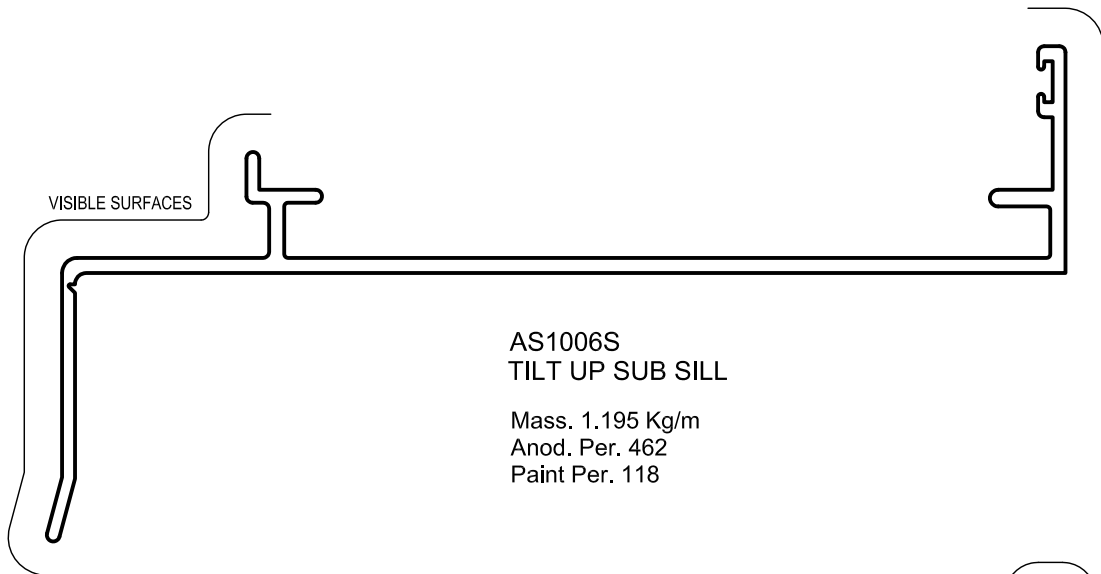
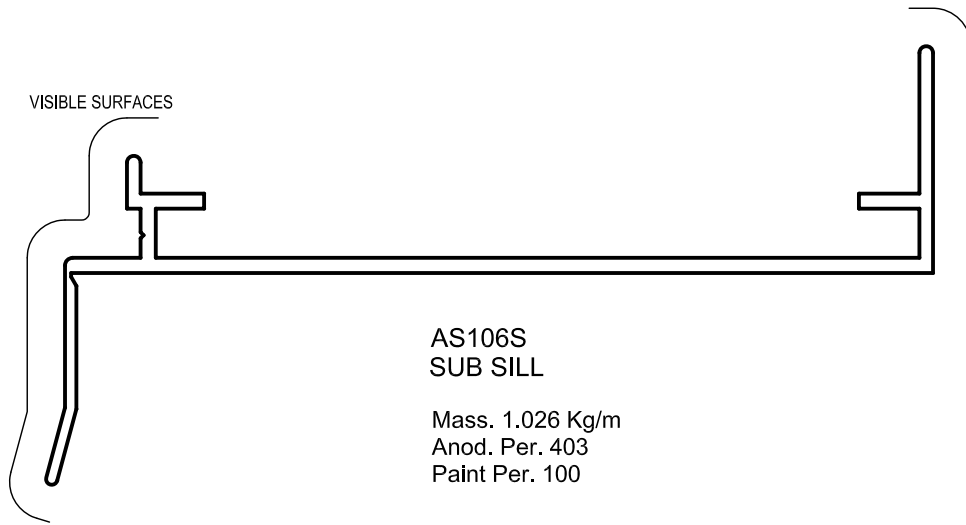

EXTRUSION PROFILES

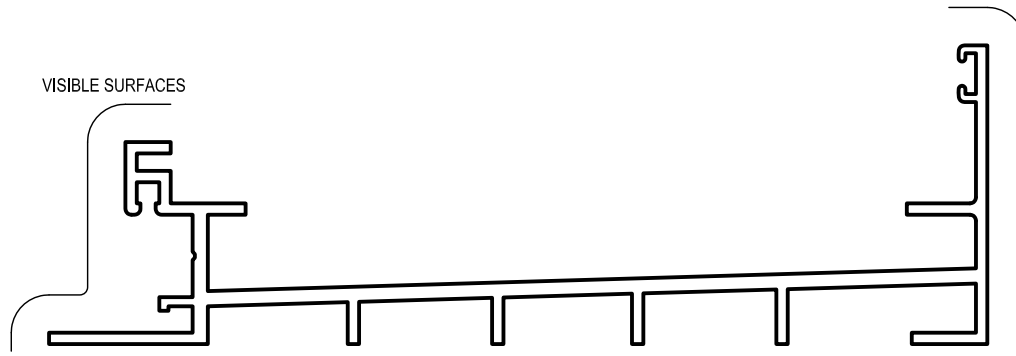

AS332S
SUB SILL

Mass. 1.227 Kg/m
Anod. Per. 529
Paint Per. 124

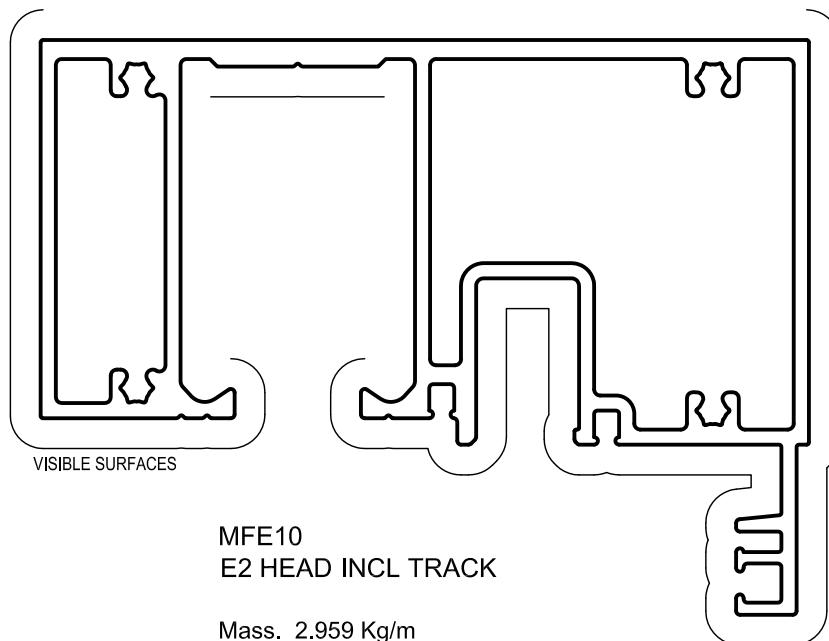

MFE10
E2 HEAD INCL TRACK

Mass. 2.959 Kg/m
Anod Per. 580
Paint Per. 379

EXTRUSION PROFILES

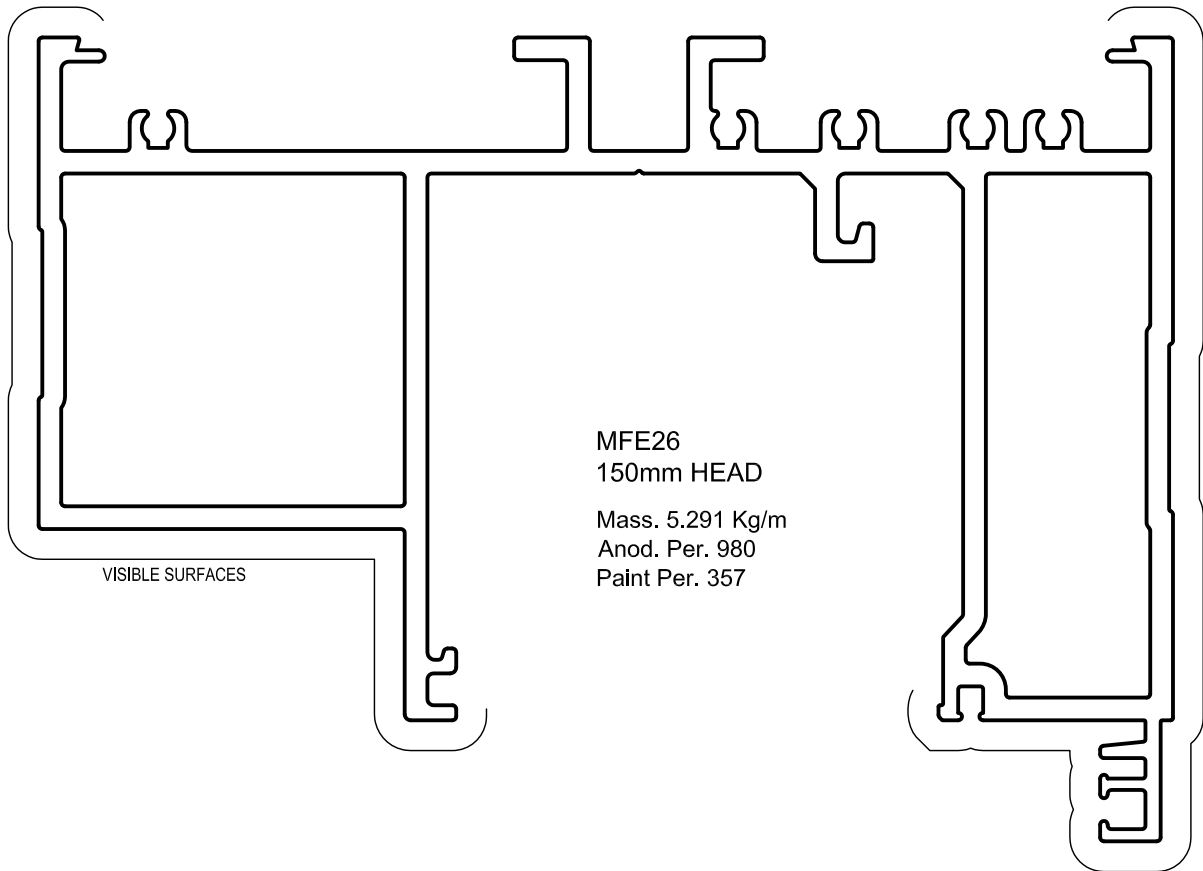

MFE26
150mm HEAD

Mass. 5.291 Kg/m
Anod. Per. 980
Paint Per. 357

VISIBLE SURFACES

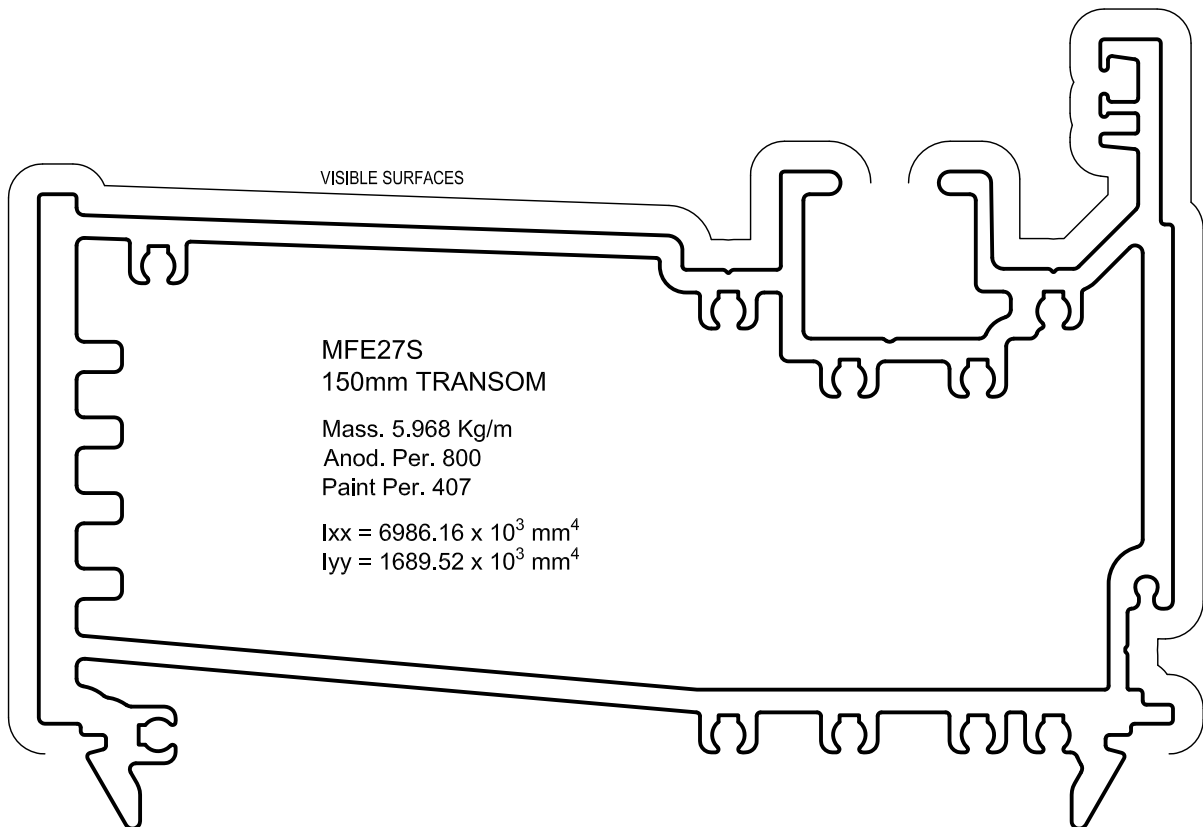

VISIBLE SURFACES

MFE27S
150mm TRANSOM

Mass. 5.968 Kg/m
Anod. Per. 800
Paint Per. 407

$I_{xx} = 6986.16 \times 10^3 \text{ mm}^4$
 $I_{yy} = 1689.52 \times 10^3 \text{ mm}^4$



Aluminium Specialties Group Pty Ltd

Call 1300 ALSPEC (257732)

SYDNEY

3 Alspec Place
Eastern Creek
NSW 2766
t 02 9834 9500
f 02 9834 9555
sydney@alspec.com.au

BRISBANE

8-22 Jutland Street
Loganlea
QLD 4131
t 07 3089 4900
f 07 3089 4999
brisbane@alspec.com.au

PERTH

30 Holder Way
Malaga
WA 6090
t 08 9209 9100
f 08 9209 9199
perth@alspec.com.au

NEWCASTLE

95 Griffiths Road
Lambton
NSW 2299
t 02 4952 9111
f 02 4952 9728
newcastle@alspec.com.au

TOWNSVILLE

28 Camuglia Street
Garbutt
QLD 4814
t 07 3089 4965
f 1300 131 747
townsville@alspec.com.au

ADELAIDE

1 Pope Court
Beverley
SA 5009
t 08 8150 6960
f 08 8150 6999
adelaide@alspec.com.au

MELBOURNE

26-40 Pound Road West
Dandenong South
VIC 3175
t 03 8787 6333
f 03 8787 6399
melbourne@alspec.com.au

CAIRNS

11 Southgate Close
Woree
QLD 4868
t 07 4037 6666
f 07 4037 6699
cairns@alspec.com.au

DARWIN

25 Bishop Street
Woolner
NT 0820
t 08 8941 7300
f 08 8941 7322
darwin@alspec.com.au

alspec
ALUMINIUM SYSTEMS
SPECIALISTS

alspec.com.au

ALSPEC ALUMINIUM SYSTEMS

TECHNICAL MANUAL

HAWKESBURY plus

COPYRIGHT

This Technical manual remains the property of Aluminium Specialties Group Pty Limited and contains privileged information which is the subject of copyright and the manual or any part thereof may not be reproduced, copied or loaned in any form without the written permission of Aluminium Specialties Group Pty Limited.

This manual is to be returned to Aluminium Specialties Group Pty Limited when requested.

DISCLAIMER

Whilst every effort has been made to ensure the technical details contained within this manual are accurate, Aluminium Specialties Group Pty Limited can take no responsibilities for any loss or damage whatsoever arising as a result of any errors contained in this manual.

Also, interpretation of standards or codes within this manual is Aluminium Specialties Group Pty Limited interpretation for such codes. Responsibility for code compliance remains with the user of this manual. In some cases product dimensions may vary or be changed without notice. The user of this manual should not act or rely upon on any information contained in this manual without first obtaining appropriate professional advice relating to their particular circumstances.

Aluminium Specialties Group Pty Limited disclaims all liability for loss or damage suffered by any party who acts or fails to act in reliance of this manual.

Issued to:

.....

ALSPEC contact:

Date:

Manual reference number:

ALSPEC ALUMINIUM SYSTEMS

TECHNICAL MANUAL

HAWKESBURY plus

CONTENTS

- 1.0 TECHNICAL MANUAL RELEASE NOTES**

- 2.0 TECHNICAL DATA**
 - 2.1 SPECIFICATION**
 - 2.2 LOADING TABLES**
 - 2.2.1 MF14 L/180
 - 2.2.2 MF14 L/250
 - 2.2.3 MF27 L/180
 - 2.2.4 MF27 L/250
 - 2.2.5 MF227 L/180
 - 2.2.6 MF227 L/250
 - 2.2.7 MF70 L/180
 - 2.2.8 MF70 L/250
 - 2.2.9 MF73 L/180
 - 2.2.10 MF73 L/250

 - 2.3 TEST REPORTS RESULTS**
 - 2.3.1 Hawkesbury Plus 2 Right MF27/MF27

- 3.0 TECHNICAL DETAILS**
 - 3.1 EXTRUSIONS**
 - 3.1.1 Extrusion profiles
 - 3.1.2 Extrusion profiles
 - 3.1.3 Extrusion profiles
 - 3.1.4 Extrusion profiles
 - 3.1.5 Extrusion profiles
 - 3.1.6 Extrusion profiles
 - 3.1.7 Extrusion profiles
 - 3.1.8 Extrusion profiles

 - 3.2 HARDWARE**
 - 3.2.1 Hardware components
 - 3.2.2 Hardware components
 - 3.2.3 Hardware components
 - 3.2.4 Hardware components
 - 3.2.5 Hardware components
 - 3.2.6 Hardware components
 - 3.2.7 Hardware components
 - 3.2.8 Hardware components
 - 3.2.9 Hardware components
 - 3.2.10 Hardware components
 - 3.2.11 Hardware components
 - 3.2.12 Hardware components
 - 3.2.13 Hardware components
 - 3.2.14 Hardware components
 - 3.2.15 Hardware Selection Charts

HAWKESBURY plus

ALSPEC ALUMINIUM SYSTEMS

TECHNICAL MANUAL

HAWKESBURY plus

CONTENTS Cont.

3.2.16 Hardware Selection Charts

3.2.17 Hardware Selection Charts

3.2.18 Hardware Selection Charts

3.3 ELEVATIONS

3.3.1 Typical Elevations

3.4 GENERAL ARRANGEMENT DRAWINGS

3.4.1 Typical head detail

3.4.2 Typical sill detail

3.4.3 Typical L.H. jamb detail

3.4.4 Typical hinge & intermediate stile details

3.4.5 CE23 Weatherseal arrangement detail

3.4.6 Typical lock meeting stile

3.4.7 Typical lock stile/jamb detail

3.5 CUTTING FORMULAS

3.5.1 Cutting formula – 2L or 2R

3.5.2 Cutting formula – 1L1R

3.5.3 Cutting formula – 2L1R or 1L2R

3.5.4 Cutting formula – 3L or 3R

3.5.5 Cutting formula – 2L2R

3.5.6 Cutting formula – 3L1R or 1L3R

3.5.7 Cutting formula – 3L3R

3.5.8 Cutting formula – 2L or 2R – HD Stiles

3.5.9 Cutting formula – 1L1R – HD Stiles

3.5.10 Cutting formula – 2L1R or 1L2R – HD Stiles

3.5.11 Cutting formula – 3L or 3R – HD Stiles

3.5.12 Cutting formula – 2L2R – HD Stiles

3.5.13 Cutting formula – 3L1R or 1L3R – HD Stiles

3.5.14 Cutting formula – 3L3R – HD Stiles

3.6 MANUFACTURING DRAWINGS

3.6.1 Jamb preparation

3.6.2 Adaptor preparation MFP7

3.6.3 Adaptor preparation MFP8

3.6.4 Head adaptor preparation

3.6.5 Track preparation

3.6.6 Pivot machining detail

3.6.7 MPF3 Sill drainage details

3.6.8 MPF4 Sub Sill drainage details

3.6.9 Frame Kit Sill and Head Mouldings

3.6.10 Door Stile preparation for AD1030E Spiggot

3.6.11 Door Rail preparation - single glazed

3.6.12 Door Stile preparation for AD10333DG Spiggot

3.6.13 Door Rail preparation - double glazed

HAWKESBURY plus

ALSPEC ALUMINIUM SYSTEMS

TECHNICAL MANUAL

HAWKESBURY plus

Section 1.0

TECHNICAL MANUAL RELEASE NOTES

This page is intended to record all changes to the **HAWKESBURY PLUS** technical manual pages. It is therefore critical that all changes are recorded in the below AMENDMENTS box prior to release to our customer.

Changes or additions to this manual will be itemised with a brief description and date when the amendments were made.

It is important that a copy of this page be issued with the update and inserted as the first page in the customers technical manual.

DATE	AMENDMENT DESCRIPTION	REMOVE PAGE	INSERT NEW PAGE
30 / 04 / 2008	<i>Technical manual initial release</i>	~	~
01 / 12 / 2008	<i>Hardware page</i>	3.2.3	3.2.3
01 / 12 / 2008	<i>Typical head detail</i>	3.4.1	3.4.1
01 / 12 / 2008	<i>Typical sill detail</i>	3.4.2	3.4.2
01 / 12 / 2008	<i>Typical LH jamb detail</i>	3.4.3	3.4.3
01 / 12 / 2008	<i>Typical meeting stile detail</i>	3.4.4	3.4.4
01 / 02 / 2009	<i>Technical manual release notes amended</i>	1.0	1.0
01 / 02 / 2009	<i>Specification amended</i>	2.1	2.1
01 / 02 / 2009	<i>Loading table explanation page added</i>	2.2	2.2
01 / 02 / 2009	<i>Accessories code amended</i>	3.2.3	3.2.3
01 / 02 / 2009	<i>Contents page updated</i>	~	~
01 / 02 / 2009	<i>Hardware pages added</i>	~	3.4.4 - 3.4.11
01 / 02 / 2009	<i>Hardware selection charts added</i>	~	3.4.12 - 3.4.15
01 / 02 / 2009	<i>Typical hinge mounting details - E2+S/S</i>	3.8.1	3.8.1
01 / 02 / 2009	<i>Typical hinge mounting details - E3+S/S</i>	3.8.2	3.8.2
01 / 06 / 2009	<i>Technical manual release notes amended</i>	1.0	1.0
01 / 06 / 2009	<i>Extrusion sections and properties amended</i>	3.1.7	3.1.7
01 / 06 / 2009	<i>Glazing details D.G. image amended</i>	3.7.2	3.7.2
01 / 11 / 2009	<i>Contents page updated - 3.6.8 added</i>	~	~
01 / 11 / 2009	<i>Technical manual release notes amended</i>	1.0	1.0
01 / 11 / 2009	<i>Frame kit notes added</i>	3.6.1	3.6.1
01 / 11 / 2009	<i>Frame kit sill & head mouldings</i>	3.6.8	3.6.8
01 / 02 / 2012	<i>Technical Manual updated for re-printing</i>	ALL	ALL
01 / 06 / 2015	<i>Cover page updated</i>	Cover Page	Cover Page

EXTRUSION PROFILES

VISIBLE SURFACE

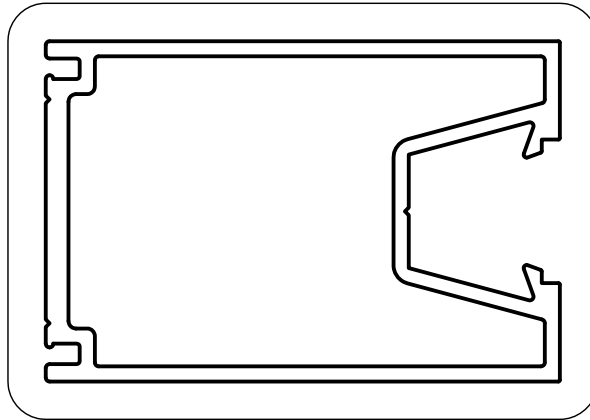

**MF14
FOLDING DOOR STILE**

Mass. 1.565 Kg/m
Anod. Per. 298
Paint Per. 226

$I_{xx} = 167.90 \times 10^3 \text{mm}^4$

VISIBLE SURFACE

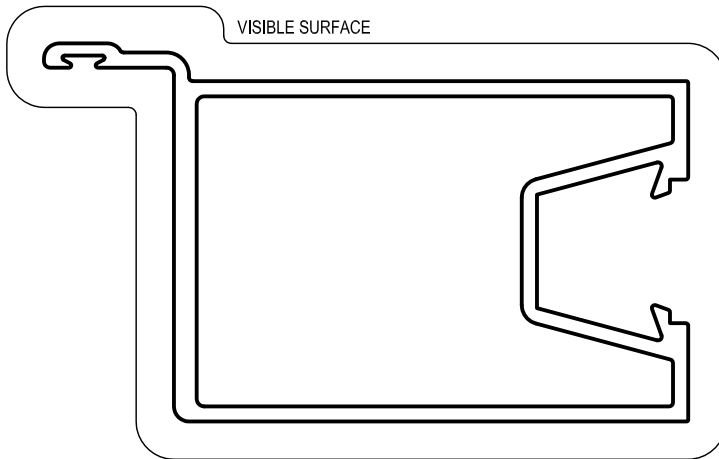

**MF16
MEETING STILE**

Mass. 1.649 Kg/m
Anod. Per. 324
Paint Per. 260

$I_{xx} = 191.50 \times 10^3 \text{mm}^4$

VISIBLE SURFACE

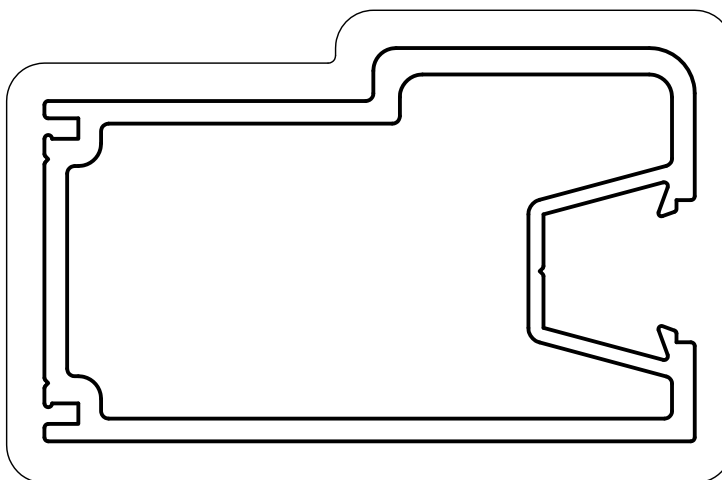

**MF27
HEAVY DUTY DOOR STILE**

Mass. 2.419 Kg/m
Anod. Per. 342
Paint Per. 273

$I_{xx} = 341.00 \times 10^3 \text{mm}^4$

NOTE: FABRICATION TIPS FOR MF27 & MF227

THE ESCUTCHEON OF THE DUAL POINT LOCK WILL NOT FIT ON MF27 AND MF227 HEAVY DUTY STILES IN AN INWARD OPENING DOOR SET. A NEAT HOLE NEEDS TO BE MILLED FOR THE EURO CYLINDER.

EXTRUSION PROFILES

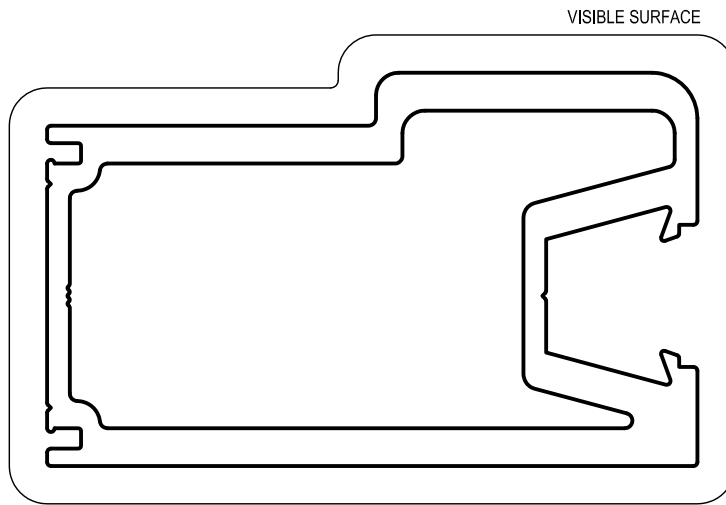

**MF227
EXTRA H.D. DOOR STILE**

Mass. 3.581 Kg/m
Anod. Per. 342
Paint Per. 273

$I_{xx} = 478.50 \times 10^3 \text{mm}^4$

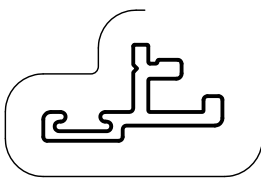

**MFA29
MEETING STILE
ADAPTOR**

Mass. 0.215 Kg/m
Anod. Per. 100
Paint Per. 100

VISIBLE SURFACE

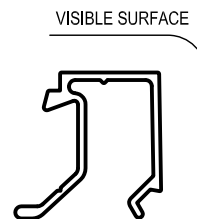

**MF18
DOOR BEAD**

Mass. 0.180 Kg/m
Anod. Per. 122
Paint Per. 100

VISIBLE SURFACE

FOR SINGLE GLAZED DOOR
USE AD1030E SPIGGOT SET
Code No. 378047

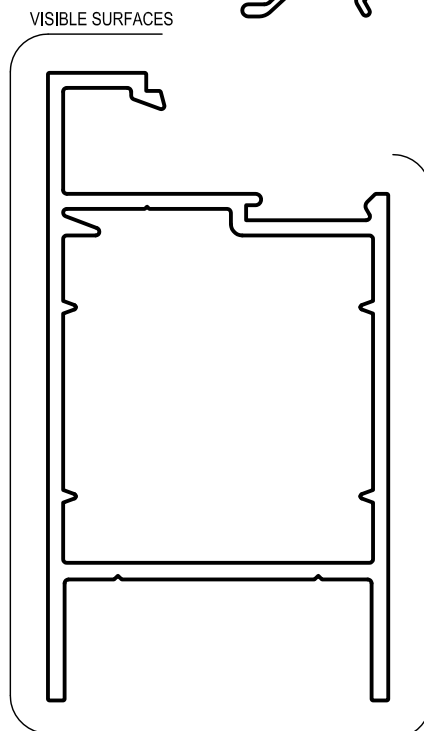

**MF17
DOOR TOP &
BOTTOM RAIL**

Mass. 1.450 Kg/m
Anod. Per. 328
Paint Per. 168

VISIBLE SURFACES

**MF75
WEATHERSEAL
SNAP ON COVER**

Mass. 0.100 Kg/m
Anod. Per. 100
Paint Per. 100

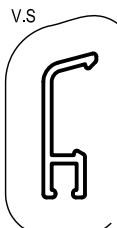

V.S

EXTRUSION PROFILES

VISIBLE SURFACE

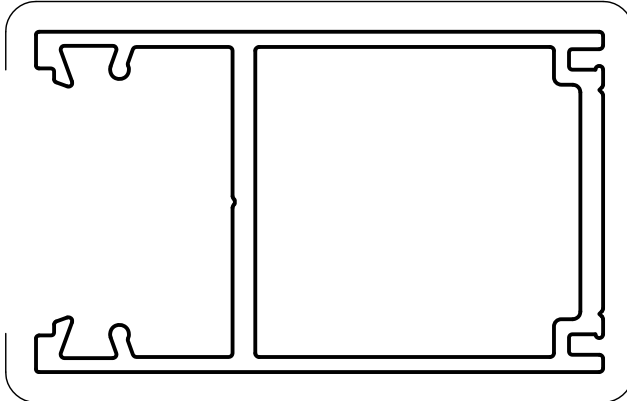

**MF70
DOUBLE GLAZED
DOOR STILE**

Mass. 1.634 Kg/m
Anod. Per. 350
Paint Per. 223

Ixx = 191.4 x 10³ mm⁴

VISIBLE SURFACE

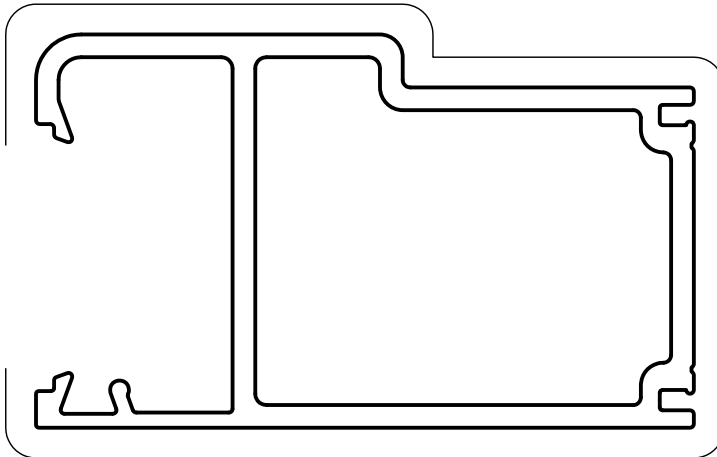

**MF73
DOUBLE GLAZED HEAVY
DUTY STILE**

Mass. 2.271 Kg/m
Anod. Per. 384
Paint Per. 257

Ixx = 334.50 x 10³ mm⁴

VISIBLE SURFACE

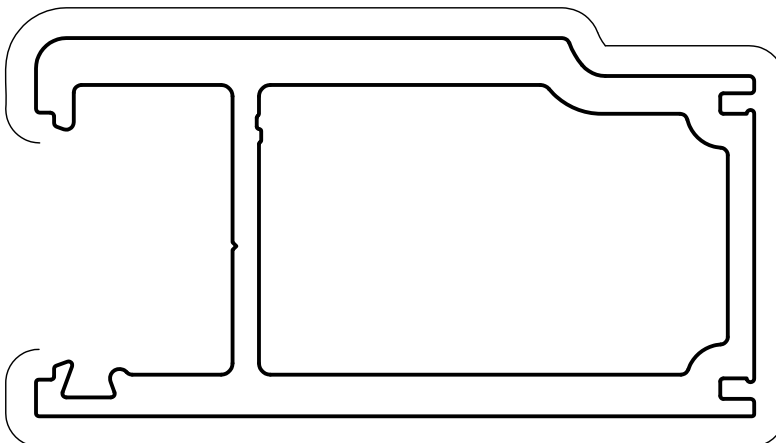

**MF77
EXTRA H/D DOUBLE
GLAZED BIFOLD STILE**

Mass. 3.702 Kg/m
Anod Per. 375
Paint Per. 271

Ixx = 539.39 x 10³ mm⁴

**FOR DOUBLE GLAZED DOOR
USE AD1033 SPIGGOT SET
Code No. 378073**

EXTRUSION PROFILES

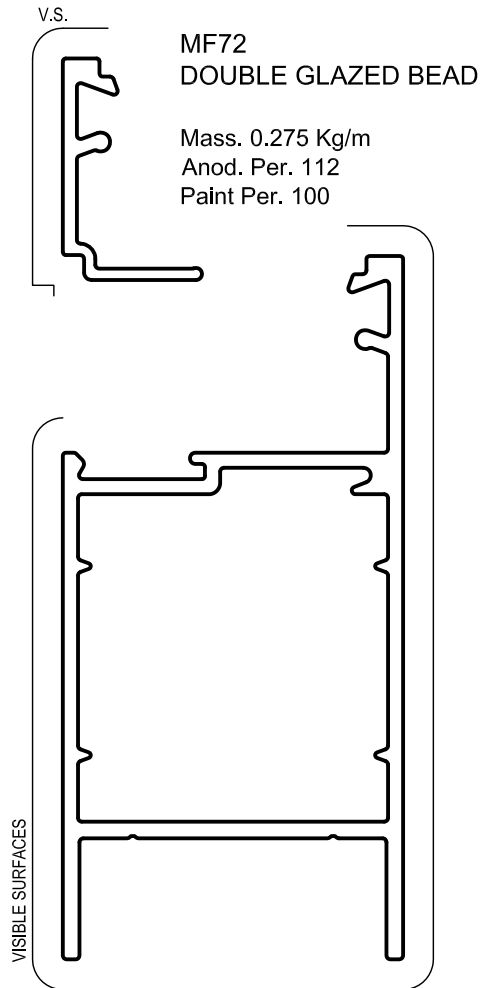

MF72
DOUBLE GLAZED BEAD

Mass. 0.275 Kg/m
Anod. Per. 112
Paint Per. 100

MF71
DOUBLE GLAZED
DOOR RAIL

Mass. 1.494 Kg/m
Anod. Per. 335
Paint Per. 170

FOR DOUBLE GLAZED DOOR
USE AD1033 SPIGGOT SET
Code No. 378073



Aluminium Specialties Group Pty Ltd

Call 1300 ALSPEC (257732)

SYDNEY

3 Alspec Place
Eastern Creek
NSW 2766
t 02 9834 9500
f 02 9834 9555
sydney@alspec.com.au

BRISBANE

8-22 Jutland Street
Loganlea
QLD 4131
t 07 3089 4900
f 07 3089 4999
brisbane@alspec.com.au

PERTH

30 Holder Way
Malaga
WA 6090
t 08 9209 9100
f 08 9209 9199
perth@alspec.com.au

NEWCASTLE

95 Griffiths Road
Lambton
NSW 2299
t 02 4952 9111
f 02 4952 9728
newcastle@alspec.com.au

TOWNSVILLE

28 Camuglia Street
Garbutt
QLD 4814
t 07 3089 4965
f 1300 131 747
townsville@alspec.com.au

ADELAIDE

1 Pope Court
Beverley
SA 5009
t 08 8150 6960
f 08 8150 6999
adelaide@alspec.com.au

MELBOURNE

26-40 Pound Road West
Dandenong South
VIC 3175
t 03 8787 6333
f 03 8787 6399
melbourne@alspec.com.au

CAIRNS

11 Southgate Close
Woree
QLD 4868
t 07 4037 6666
f 07 4037 6699
cairns@alspec.com.au

DARWIN

25 Bishop Street
Woolner
NT 0820
t 08 8941 7300
f 08 8941 7322
darwin@alspec.com.au

alspec
ALUMINIUM SYSTEMS
SPECIALISTS

alspec.com.au