

## CUSTOMER TECHNICAL MEMO # 155

**Subject: Swan Manufacturing Drawing Amendment**

**Date:** 31/10/12

**From:** Product Development

Please note we have made an amendment to the Swan Commercial Door Technical Manual.

On page 3.6.11 - Frame Preparation 11 we have made a few dimensional changes locating the door spigot.

Attached are revised pages 1.0 Technical Manual Release Notes and 3.6.11/3.6.12 Frame Preparation Drawings. When printing please set your printer to double sided and you will be able to easily remove and replace the pages in your existing Technical Manual.

If you have any questions please do not hesitate to contact your local ALSPEC Area Manager or Sales Office.



# ALSPEC ALUMINIUM SYSTEMS

## TECHNICAL MANUAL

### SWAN COMMERCIAL DOOR

Section 1.0

#### TECHNICAL MANUAL RELEASE NOTES

This page is intended to record all changes to the **SWAN COMMERCIAL DOOR** technical manual pages. It is therefore critical that all changes are recorded in the below AMENDMENTS box prior to release to our customer.

Changes or additions to this manual will be itemised with a brief description and date when the amendments were made.

It is important that a copy of this page be issued with the update and inserted as the first page in the customers technical manual.

DATE	AMENDMENT DESCRIPTION	REMOVE PAGE	INSERT NEW PAGE
01 / 09 / 2008	Technical manual initial release	~	~
01 / 02 / 2009	Technical manual release notes updated	1.0	1.0
01 / 02 / 2009	New Door Stop extrusion added	3.1.13	3.1.13
01 / 02 / 2009	Seal selection chart updated	3.1.15	3.1.15
01 / 02 / 2009	Spigot kit selection chart added	3.2.6	3.2.6
01 / 02 / 2009	Specification amended	2.1	2.1
01 / 06 / 2009	Technical manual release notes updated	1.0	1.0
01 / 06 / 2009	MF70 extrusion amended	3.1.9	3.1.9
01 / 06 / 2009	Detail 21 MF70 extrusion & formula amended	3.4.9	3.4.9
01 / 06 / 2009	MF71 extrusion amended	3.6.11	3.6.11
01 / 06 / 2009	MF70 extrusion amended	3.6.12	3.6.12
01 / 11 / 2012	Technical manual release notes updated	1.0	1.0
01 / 11 / 2012	MF71 dimensions amended	3.6.11	3.6.11



## FRAME PREPARATION 11

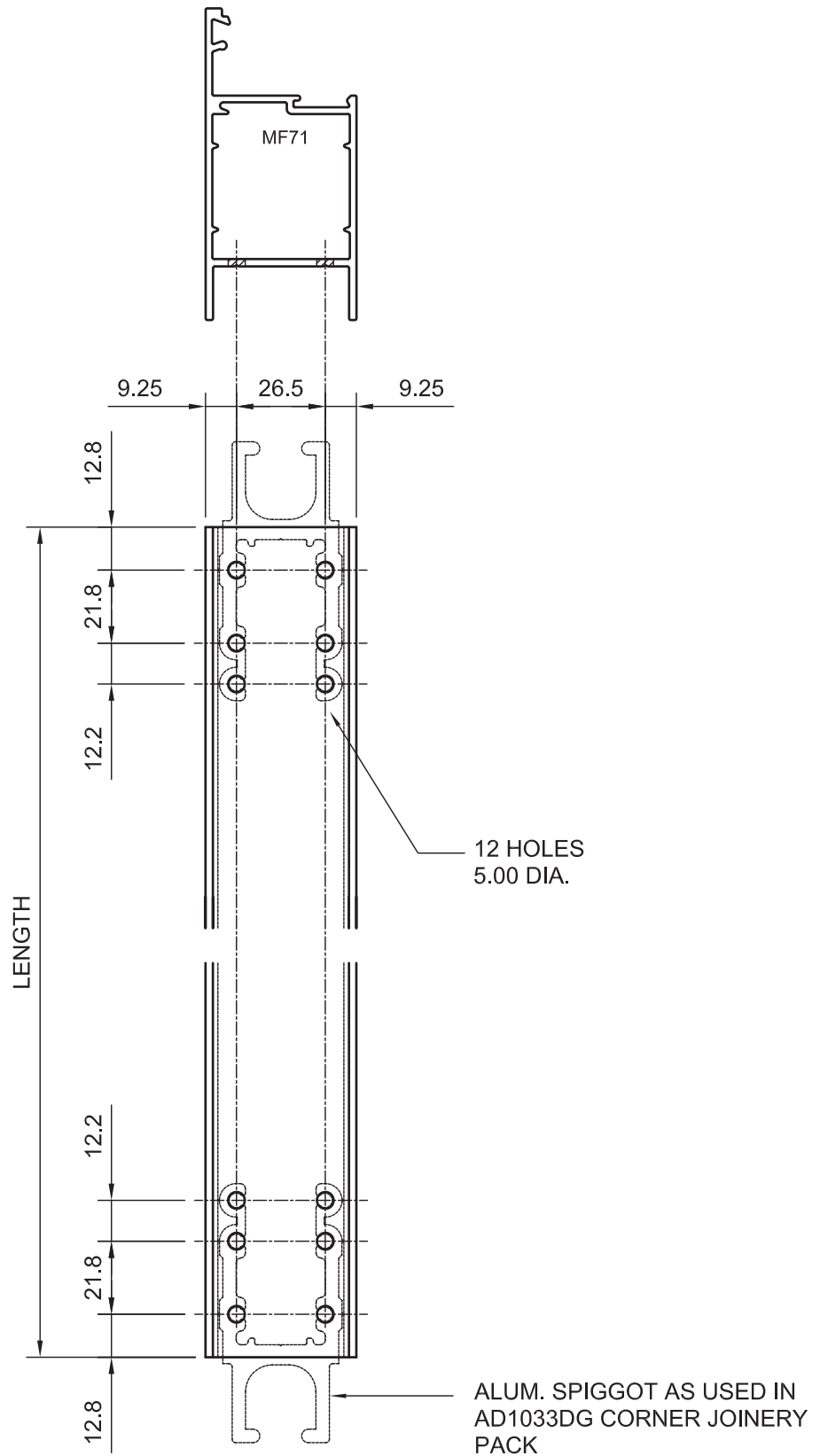

## FRAME PREPARATION 12

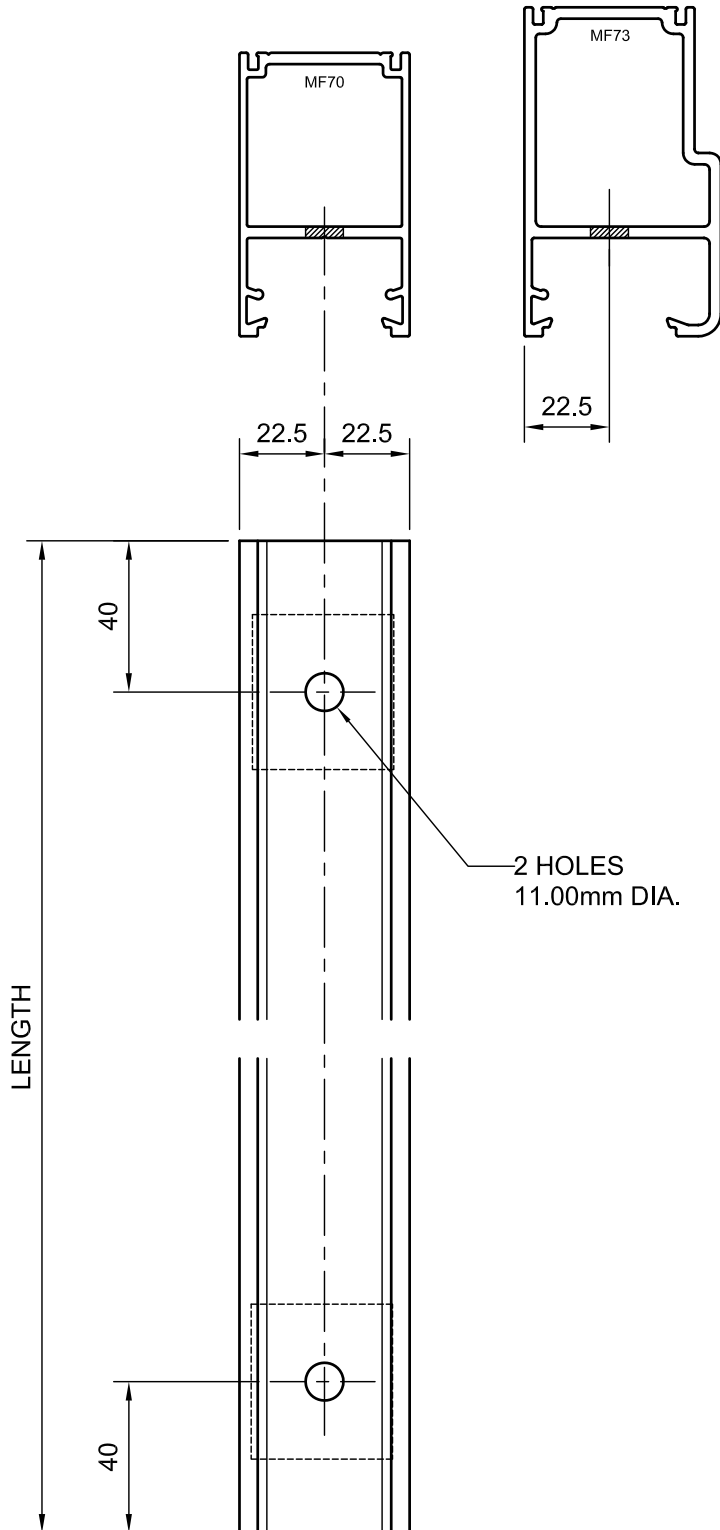

HALF SCALE