

CUSTOMER TECHNICAL MEMO # 184

Subject: ASW10 AWNING ADAPTOR (EXTENDED LEG) – New Die

Date: 11/10/13

From: Product Development

Please note we have added ASW10 McArthur Awning Adaptor to the awning / casement suit.

This section was developed to eliminate the 3mm gap created by the overhang of ASW43 winder adaptor when using ASW2, refer Attached drawings.

If you have any questions please do not hesitate to contact your local ALSPEC Area Manager or Sales Office.

Extrusions

ECO285
50mm AWNING
ADAPTOR

Mass. 0.456 Kg/m
Anod. Per. 202
Paint Per. 103

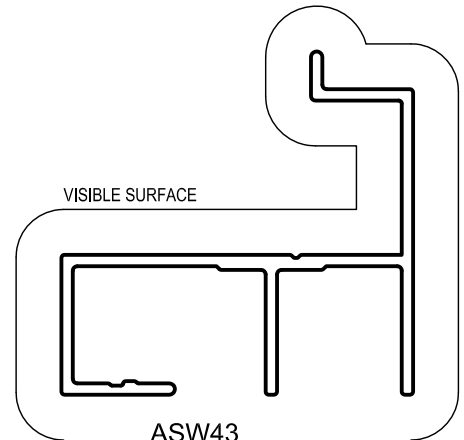
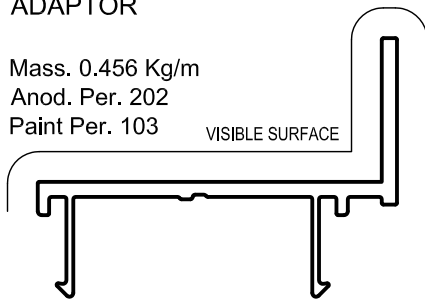

ASW43
AWNING WINDER
ADAPTOR

Mass. 0.624 Kg/m
Anod. Per. 299
Paint Per. 160

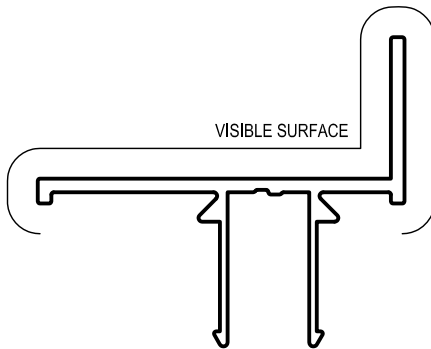

ASW10
SASH ADAPTOR
(Suits ASW44 Sash
& ASW43 Winder Packer)

Mass. 0.491 Kg/m
Anod. Per. 232
Paint Per. 100

AWNING SASH ADAPTOR SELECTION CHART

SECTION	DESCRIPTION
AS581	DERWENT 76mm CENTRE GLAZED 35mm SASH
ASW2	McARTHUR 101.6mm CENTRE GLAZED 35mm SASH
ECO222	ECOFRAME 400 CENTRE DOUBLE GLAZED 50mm SASH
ECO223	ECOFRAME 400 CENTRE DOUBLE GLAZED 35mm SASH
EC0223	ECOFRAME 600 CENTRE DOUBLE GLAZED WITH ASW57, ASW58 & ASW59 SASH ONLY
ECO285	ECOFRAME 600 CENTRE DOUBLE GLAZED 50mm SASH
AS327	HUNTER 100 & 150mm FRONT SINGLE GLAZED 35mm SASH
AS344	HUNTER 100 & 150mm FRONT SINGLE GLAZED 50mm SASH
AS321	HUNTER 100 & 150mm FRONT SINGLE GLAZED 50mm SASH
AS1321	HUNTER 100 & 150mm FRONT DOUBLE GLAZED 50mm SASH
AS1322	HUNTER 100 & 150mm FRONT DOUBLE GLAZED 35mm SASH
AS851	McARTHUR 101.6mm CENTRE GLAZED 50mm SASH
ASW10	McARTHUR 101.6mm CENTRE GLAZED ASW44 SASH

