

CUSTOMER TECHNICAL MEMO # 208

Subject: CSD INTERLOCK ANTI-LIFT BLOCK

Date: 25-06-2014

Good Afternoon,

We have received feedback from our customers that the original design of our CSD INTERLOCK ANTI-LIFT BLOCK was prone to damage of the fixing feet during transport to the installation site.

We have improved the design of this product so that it is now installed onsite to avoid the possibility of damaging the fixing feet during transport.

Item Number: 1378920

Item Name: CSD INTERLOCK ANTI-LIFT BLOCK

New Item

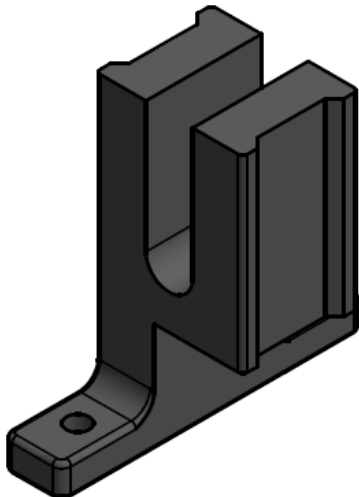

Old Item

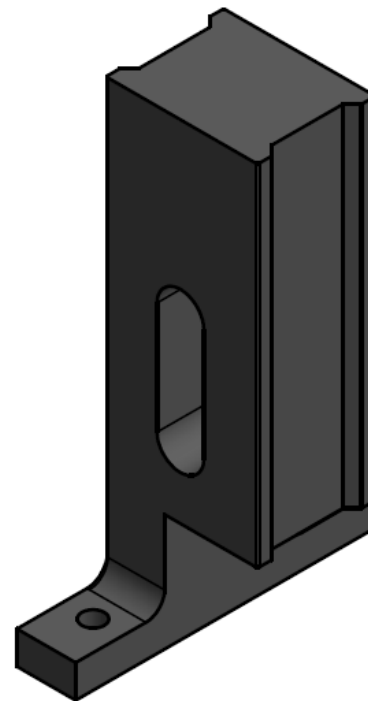

Regards,
Product Development