

RETAIL COUNTER SCREEN BARRIER



Dear Valued Customers,

With the COVID-19 pandemic and retail outlets looking to keep their staff safe, we have developed the "Pro-Splash" airborne contamination protection barrier for counter tops.

Please see the attached flyer for further product information and how to order.

Regards,

Leigh Todd

Danmac - General Manager

pro-splash

AIRBORNE CONTAMINATION PROTECTION



pro-splash

AIRBORNE CONTAMINATION PROTECTION



FULLY FRAMED FIX PANELS

To order or for more information call:

1300 139 706

visit: danmac.com.au

99 Frankston Gardens Drive,
Carrum Downs VIC 3201

Phone: 03 9775 1223 | Fax: 03 9775 1445



POWERED BY ALSPEC

pro-splash











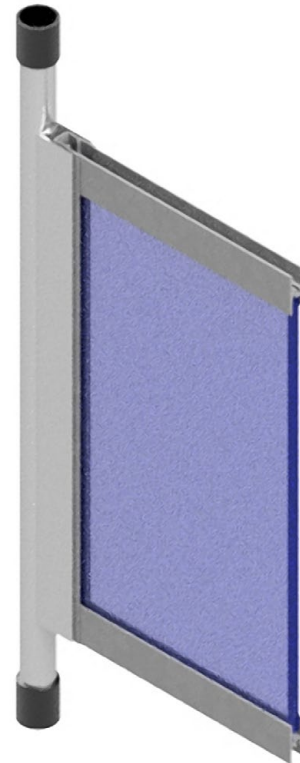

excellence. innovation. custom design.

AIRBORNE CONTAMINATION PROTECTION

The pro-splash is designed for environments where protection from coughing or sneezing and general airborne fluid contamination is of the utmost importance. Manufactured from the finest materials, the shield is virtually unbreakable serving a dual purpose of protecting against bio-hazards as well as physical threats from the public.

Top View



Code/Diagram	Description
DRC 	Return Channel (4.3m)
DSR 	Sash Rail (3.8m)
DMIST 	Mirror Stile (4.1m)
DR19 	19mm Rod (4.0m)
DUC10 	Wall Channel (4.3m)
DPR 	Pop Rivets 1,000/box
DFS1.5 	Frame Screws 6g x 1.5" SS CSK - 1,000/box
DPR1800 	Polished Rod
FSB-1 	Wall to Rod Stabilizer

